



GLI SPECIALISTI DEL NOLEGGIO E NON SOLO

Macchine e attrezzature
edili e industriali
a noleggio

GIURIATO®

Una nuova edilizia

GLI SPECIALISTI DEL NOLEGGIO E NON SOLO...

INDICE

- 2. Gli specialisti del noleggio e non solo...
- 4. I nostri corsi di formazione
- 7. Movimento terra
Sollevamento
- 39. Gru edili
Piattaforme aeree
- 51. Sistemi di casseratura
Armamento solaio
Ponteggi & trabattelli
- 75. Gruppi elettrogeni
Macchine edili
Attrezzature edili
Box e recinzioni
- 103. Macchine agricole
Attrezzature agricole
- 110. Non solo Noleggio
I nostri servizi

GIURIATO[®]
Una nuova edilizia

DAL **1966**

GLI SPECIALISTI DEL NOLEGGIO E NON SOLO...

Da sempre il nostro obiettivo è occuparci delle aziende. La nostra è una storia che inizia con l'edilizia, il settore storico. Negli anni, oltre alla vendita di macchine ed attrezzature, abbiamo introdotto il noleggio, la consulenza e l'assistenza.

Oltre ad un catalogo con 30.000 prodotti, disponiamo di due punti vendita, **Zanè** e **Altavilla**, garantendo una copertura di fornitura praticamente illimitata.

È attivo il negozio on line **giuriatostore.com** per soddisfare qualunque esigenza anche al di fuori del nostro territorio tradizionale. Oggi siamo in grado di offrire una vasta gamma di servizi specifici per il settore industriale. Sicurezza ed antinfortunistica, consulenza, progettazione e montaggio di ponteggi e linee vita, corsi di formazione per la sicurezza sul posto di lavoro a tutti i livelli.

I nostri agenti sono a vostra disposizione per presentarvi tutte le soluzioni Giurato:

NUMERO DIRETTO ☎ **Zanè: 0445 315733**

NUMERO DIRETTO ☎ **Altavilla: 0444 1755307**



Sede di Zanè



Filiale di Altavilla Vic.

UNA NUOVA EDILIZIA

Sempre più vicini agli imprenditori e alle aziende. Nati nel 1965 l'Azienda conta oggi **33 figure professionali** qualificate e specializzate per servire i nostri clienti e dare loro ogni tipo di supporto ed assistenza sia nella nostra sede di **Zanè** che nella filiale di **Altavilla Vicentina**.

SEDE: via M. Summano, 101
36010 - Zanè (VI)
t. +39 0445 315700
info@giurato.it

FILIALE: via Olmo, 41 S.R.11
36077 - Altavilla Vic.na (VI)
t. +39 0444 522880
info.altavilla@giurato.it

I NOSTRI SERVIZI

VENDITA MACCHINE E ATTREZZATURE EDILI

VENDITA MATERIALI EDILI

NOLEGGIO

ASSISTENZA DI MACCHINE E ATTREZZATURE EDILI

CONSULENZA E PROGETTAZIONE LINEE VITA

CORSI DI AGGIORNAMENTO E FORMAZIONE

SICUREZZA

FORNITURE INDUSTRIALI



www.giurato.it

www.giuratostore.com

I NOSTRI CORSI DI FORMAZIONE

L'IMPORTANZA DELLA FORMAZIONE

Giuriato in collaborazione con **Fesica Confisal**, ente di formazione riconosciuto dall'accordo **Stato Regioni 22/02/2012**, organizza corsi di formazione specifici per lavoratori sulla sicurezza nel posto di lavoro, permettendo alle aziende interessate di adempiere a tale obbligo, come previsto dal **Testo Unico sulla Sicurezza D. Lgs. 81 del 9.04.2008**. Il datore di lavoro deve provvedere affinché il lavoratore riceva adeguata formazione sui rischi per la salute e sicurezza connessi all'attività generale dell'impresa e sulle nuove procedure previste dal citato Testo Unico sulla salute e sicurezza nei luoghi di lavoro.

SICUREZZA

antincendio basso rischio	4 ore
antincendio medio rischio	8 ore
d.p.i anticaduta per lavori in quota	8 ore
dirigenti	16 ore
preposti	8 ore
formazione generale	4 ore
formazione specifica rischio alto+generale	16 ore
formazione specifica rischio medio+generale	12 ore
formazione specifica rischio basso+generale	8 ore
linea vita	4 ore
pimus (ponteggi)	28 ore
primo soccorso modulo A	16 ore
primo soccorso modulo B e C	12 ore
rls rappresentante lavoratori sicurezza	32 ore
rspp resp. servizio prevenzione e protezione alto rischio	48 ore
rspp resp. servizio prevenzione e protezione basso rischio	16 ore
rspp resp. servizio prevenzione e protezione medio rischio	24 ore
addetto alla segnaletica stradale	8 ore
preposto alla segnaletica stradale	12 ore
spazi confinanti	8 ore
trabattello	4 ore



MACCHINE E ATTREZZATURE AGRICOLE

informazione / formazione attrezzatura lavoro agricola	4 ore
informazione / formazione attrezzatura lavoro motosega	2 ore
trattori su ruote	8 ore
trattori su ruote e cingoli	13 ore

MACCHINE E ATTREZZATURE EDILI

carrelli elevatori / movimentatori telescopici telescopici	16 ore
carrelli elevatori (muletti)	12 ore
carroponte	8 ore
gru edili rotazione alta e bassa	14 ore
gru idrauliche su camion	12 ore
macchine movimento terra pesante + formazione generale	16 ore
macchine movimento terra + formazione generale	12 ore
movimentazione manuale carichi	4 ore
piattaforme con / senza stabilizzatori	10 ore

AGGIORNAMENTI

rspp resp. servizio prevenzione e protezione medio rischio	10 ore
rspp resp. servizio prevenzione e protezione basso rischio	6 ore
rspp resp. servizio prevenzione e protezione alto rischio	14 ore
rls rappresentante lavoratori sicurezza	4 ore
pimus	4 ore
piattaforme	4 ore
movimento terra	4 ore
gru idrauliche su camion	4 ore
gru edili	4 ore
antincendio medio	5 ore
preposto	4 ore
carrelli elevatori	4 ore
trattori su ruote / cingoli	4 ore
primo soccorso - rischio modulo B	4 ore
primo soccorso - rischio modulo A	6 ore
carrelli elevatori / movimentatori telescopici	4 ore





MOVIMENTO TERRA



SOLLEVAMENTO

MINIPALE GOMMATE

MOD. G 1640

GIURIATO
Una nuova edilizia

CARATTERISTICHE:
Minipala gommata



MODELLO	PESO Ql	POTENZA Hp	ALT. SCARICO mm	LARGHEZZA mm
G 1640	12,9	22	1810	920

SCHEDA TECNICA G 1640

A Altezza massima benna	3110 mm
B Altezza perno benna	2445 mm
C Altezza totale con cabina	1810 mm
D Luce (tra le ruote) libera	170 mm
E Lunghezza totale con benna	2005 mm
F Lunghezza totale senza benna	1970 mm
G Interasse	778 mm
H Sbraccio	410 mm
J Angolo di scarico	43°
R Altezza di scarico filo benna	1890 mm

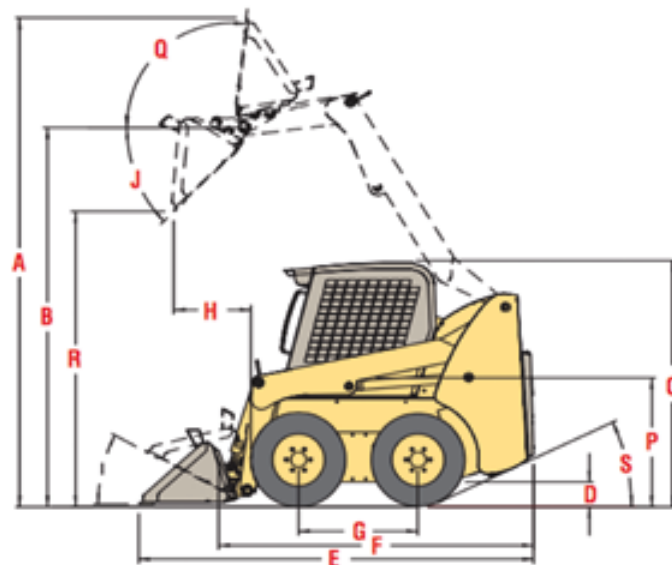

EXTRA: Disponibili rampe di carico in alluminio

MINIESCAVATORI CINGOLATI

MOD. 300.9 D

CAT Rental

CARATTERISTICHE:
Miniescavatore cingolato Caterpillar



+ ACCESSORI



Demolitore idraulico
Socomec DMS 50



MODELLO	PESO Ql	POTENZA Hp	PROFONDITÀ DI SCAVO mm	LARGHEZZA VARIAB. mm	CINGOLATURA CARRO
300.9 D	9,5	18	1731	700 / 860	gomma

SCHEDA TECNICA 300.9 D

A	1507 mm
A*	2276 mm
D	1731 mm
E	1349 mm
F	2863 mm
G	2035 mm
H	3074 mm
P	1220 mm
N	197 mm
O	174 mm

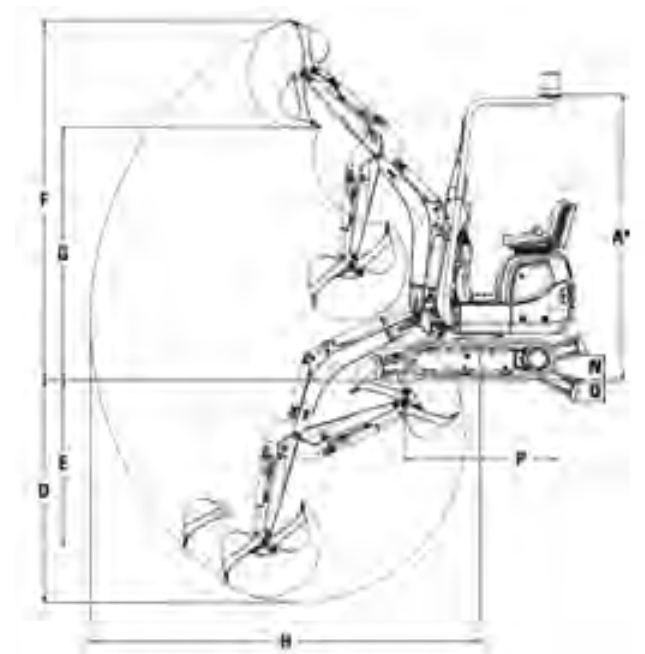

EXTRA: Disponibili rampe di carico in alluminio

MINIESCAVATORI GIROSAGOMA

MOD. 301.7D CR / 302.7D CR



CARATTERISTICHE:

Miniescavatori Caterpillar con benne in aggancio rapido

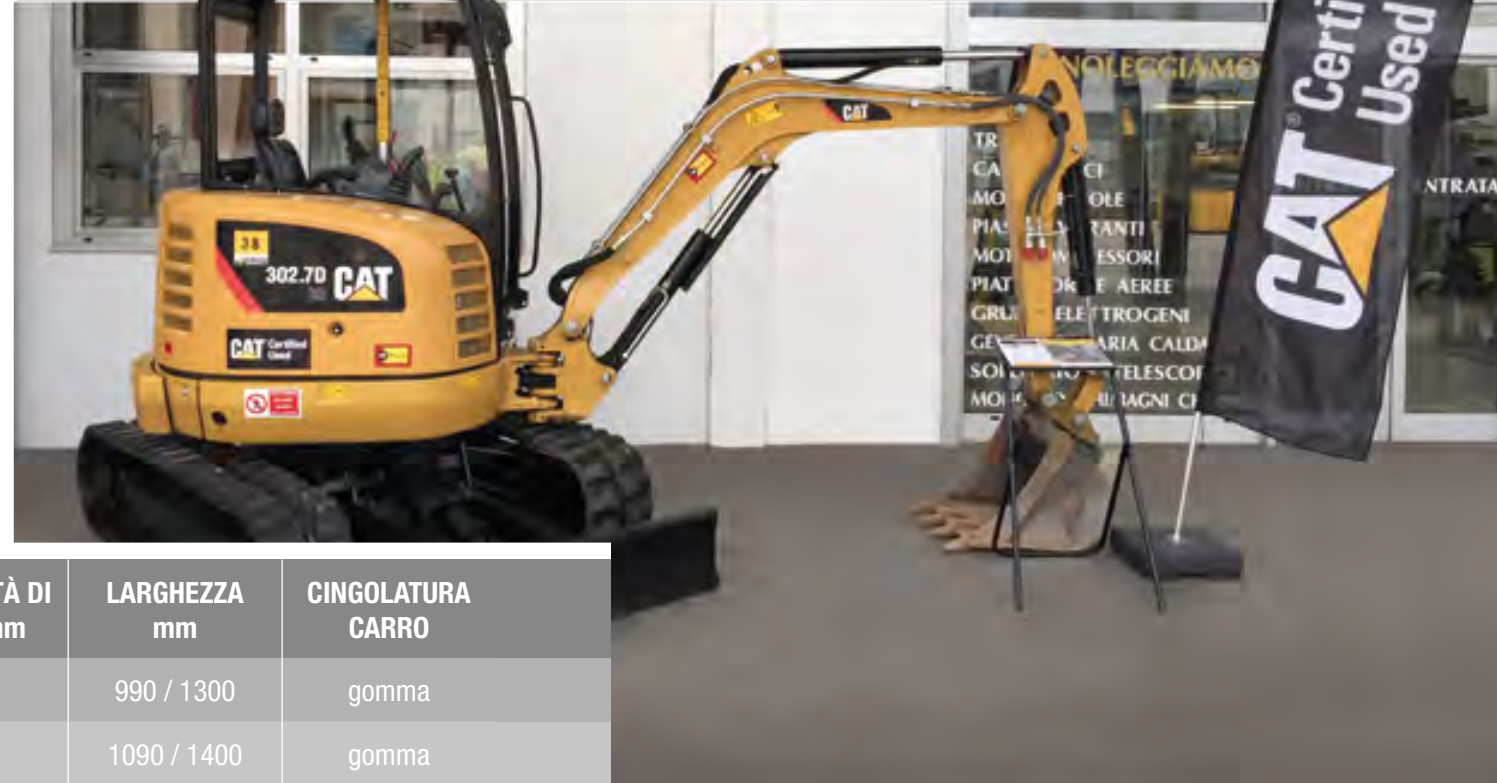

MODELLO	PESO QI	POTENZA Hp	PROFONDITÀ DI SCAVO mm	LARGHEZZA mm	CINGOLATURA CARRO
301.7D CR	16,1	17,7	2481	990 / 1300	gomma
302 CR	21	19,2	2570	1090 / 1400	gomma
302.7D CR	26,7	24,3	2744	1570	gomma

+ ACCESSORI



Demolitore idraulico Socomec DMS 95 / 165



Trivella TR 100

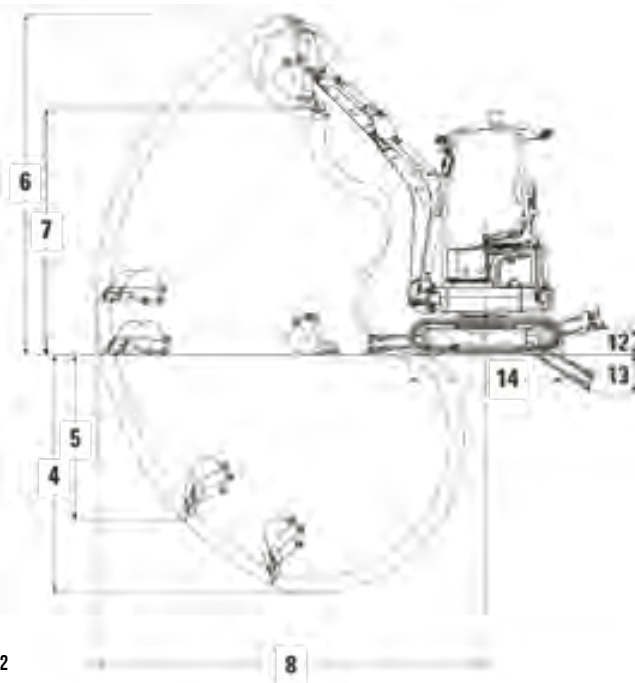

SCHEDA TECNICA

	301.7D CR	302 CR	302.7D CR
4	2481 mm	2570 mm	2744 mm
5	1718 mm	1940 mm	2152 mm
6	3548 mm	3620 mm	4300 mm
7	2555 mm	2640 mm	2970 mm
8	3995 mm	4270 mm	4805 mm
12	271 mm	285 mm	380 mm
13	390 mm	295 mm	419 mm
14	1607 mm	1850 mm	2006 mm

SCHEDA TECNICA

	301.7D CR	302 CR	302.7D CR
1	2362 mm	2300 mm	2408 mm
2	990 / 1300 mm	1090/1400 mm	1570 mm
3	3584 mm	3880 mm	4255 mm
9	660 / 722 mm	670 / 750 mm	760 mm
10	533 mm	500 mm	764 mm
11	418 mm	650 mm	533 mm

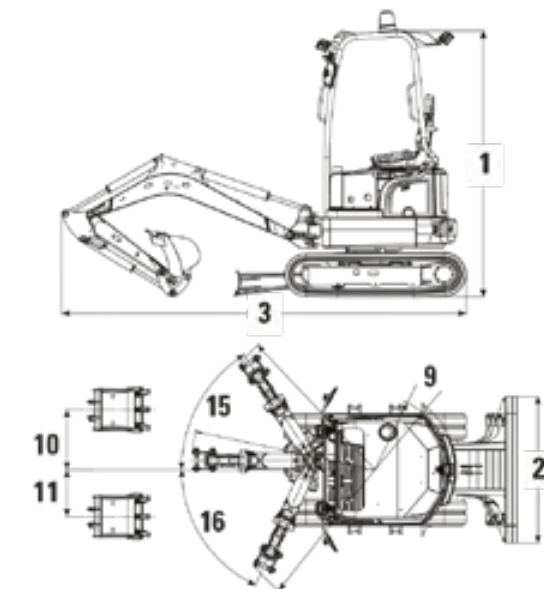

MINIESCAVATORI IN SAGOMA

MOD. 303E CR / 303.5E CR / 305E2 CR



CARATTERISTICHE:

Miniescavatori Caterpillar con benne in aggancio rapido e valvole di blocco



+ ACCESSORI

Demolitore idraulico Socomec
DMS 165 / 210 / 300

Testata trinciante
TC2-14



Pinza GMR 1300



Trivella T 5

Piastra vibrante Socomec
SPV 310



MODELLO	PESO QI	POTENZA Hp	PROFONDITÀ DI SCAVO mm	CINGOLATURA CARRO
303E CR	32,9	24,8	3200	gomma
303.5E CR	36,95	39,4	3450	gomma
305E2 CR	54,0	47,6	3890	gomma



SCHEDA TECNICA			
	303E CR	303.5E CR	305E2 CR
1	3200 mm	3450 mm	3890 mm
2	2550 mm	2650 mm	2940 mm
3	5350 mm	5500 mm	6050 mm
4	5470 mm	5620 mm	6200 mm
5	5060 mm	5110 mm	5630 mm
6	3610 mm	3670 mm	4050 mm
7	2180 mm	2220 mm	2530 mm
8	775 mm	890 mm	990 mm
9	400 mm	400 mm	420 mm
10	470 mm	470 mm	540 mm

SCHEDA TECNICA			
	303E CR	303.5E CR	305E2 CR
11	1450 mm	1700 mm	2100 mm
12	2500 mm	2500 mm	2550 mm
13	565 mm	565 mm	615 mm
14	2220 mm	2220 mm	2580 mm
15	4770 mm	4930 mm	5450 mm
16	770 mm	735 mm	785 mm
17	660 mm	660 mm	695 mm
18	300 mm	300 mm	400 mm
19	1550 mm	1780 mm	1980 mm

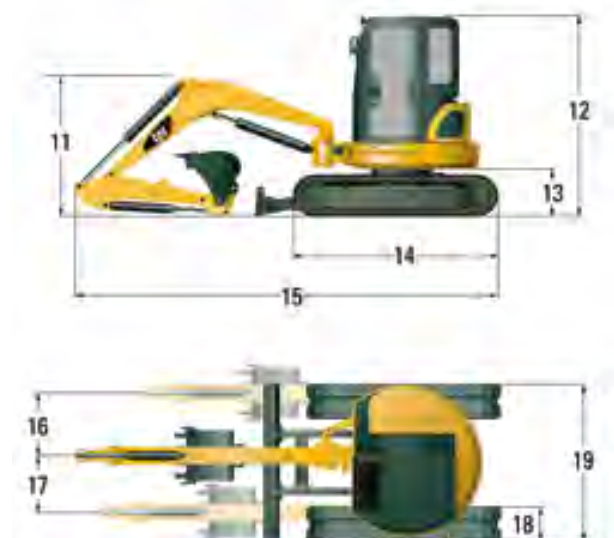



CARATTERISTICHE:

Midiescavatore Caterpillar con benne in aggancio rapido idraulico e valvole di blocco



+ ACCESSORI



Demolitore idraulico Socomec DMS 400

MODELLO	PESO QI	POTENZA Hp	PROFONDITÀ DI SCAVO mm	CINGOLATURA CARRO
308E2 CR SB	85 / 90	65	4150	gomma segmenti

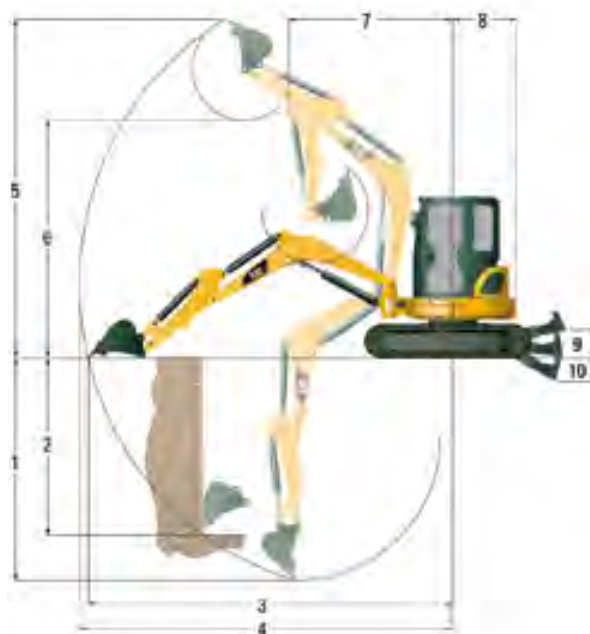

SCHEDA TECNICA 308E2 CR

1	4150 mm
2	2980 mm
3	6825 mm
4	7020 mm
5	6640 mm
6	4670 mm
7	2800 mm
8	1450 mm
9	420 mm
10	320 mm

SCHEDA TECNICA 308E2 CR

11	2280 mm
12	2550 mm
13	735 mm
14	2903 mm
15	6380 mm
16	1010 mm
17	635 mm
18	450 mm
19	2320 mm

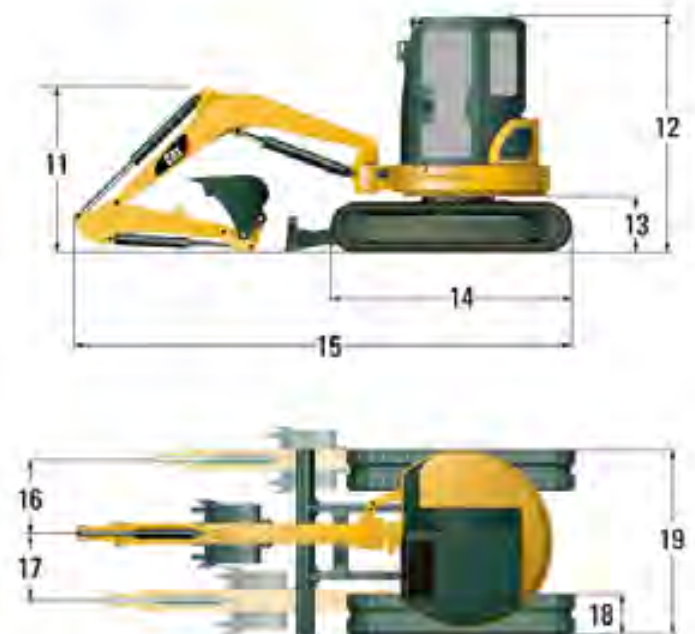

ESCAVATORI IDRAULICI

MOD. 314D LCR



CARATTERISTICHE:

Escavatore girosagoma con valvole di blocco e cingoli in ferro



Demolitore idraulico Socomec DMS 980

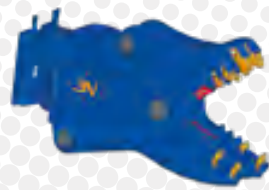

Pinza Frantumatrice modello FR09 RD

MODELLO	PESO QI	POTENZA Hp	PROFONDITÀ DI SCAVO mm	ALTEZZA DI CARICO mm	LARGHEZZA mm
314D LCR	142,4	95,6	5740	7040	2490

SCHEDA TECNICA 314D LCR

1	5740 mm
2	8440 mm
3	9470 mm
4	7040 mm
5	2250 mm
6	5550 mm
7	5080 mm



PALE GOMMATE



CARATTERISTICHE:

Pala gommata Caterpillar



MODELLO	PESO QI	POTENZA Hp	CAPACITÀ BENNA m³	LARGHEZZA mm	CINGOLATURA CARRO
908 M	63,6	74	1,2	1985	gomma

SCHEDA TECNICA 908 M

1	2650 mm
2	340 mm
3	2170 mm
4	5630 mm
5	770 mm
6	101 mm
7	2620 mm
8	3215 mm
9	3410 mm
10	33°

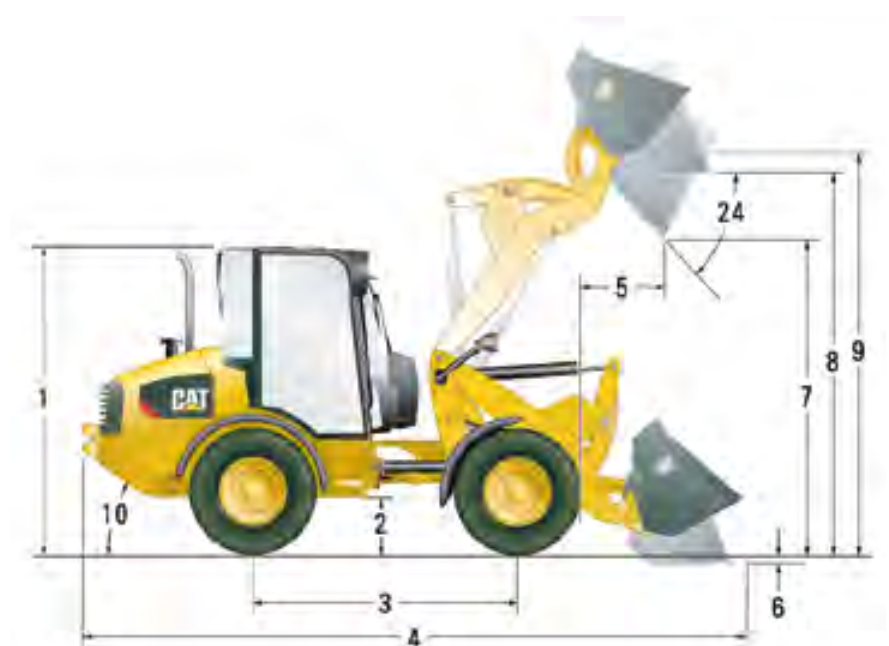

MOD. 908 M

+ ACCESSORI

Benna miscelatrice



Fresa autolivellante PL 50.20



Spazzatrice



Forche pallets



TESTATA TRINCIANTE

ACCESSORI ESCAVATORI



CARATTERISTICHE:

Scocca rinforzata, coltelli a Y per 50 q.li



MODELLO	PESO Kg	PRESSIONE Bar	PORTATA Olio	LARGHEZZA cm	INSTALLABILE su ESCAVATORE
TC 2 - 14	250	200	22 / 42	80	5 t

PINZA FRANTUMATRICE



CARATTERISTICHE:

Pinze FR09 RD per escavatore 314D LCR

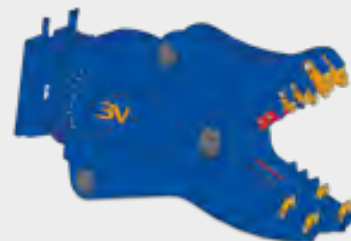

MODELLO	PESO Kg	APERTURA MAX mm	PORTATA OLIO MAX L/min	PRESSIONE ESERC. MAX Bar	ROT.	INSTALLABILE su ESCAVATORE
FR09 RD	900	655	150	340	360°	14 t

PIASTRA VIBRANTE PER ESCAVATORE



CARATTERISTICHE:

Compatta terreni, scavi, pendii in profondità

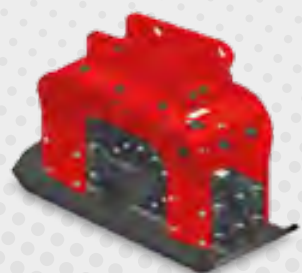

MODELLO	PESO Kg	A/B mm	PORTATA OLIO MAX L/min	PRESSIONE ESERC. MAX Bar	INSTALLABILE su ESCAVATORE
SPV 310	250	600 / 300	30 / 50	180	3,5 / 5,5 t

DEMOLITORI IDRALULICI



CARATTERISTICHE:

Unica struttura monoblocco senza tiranti, silenziati



MOD.	ENERGIA COLPO J	MAX C/min	PORT.OLIO Lt/min	PRESS. LAV. Bar	PESO Kg	DIAM. mm	ALTEZZA mm	LARGH. mm	INSTALLABILE su escavatore
DMS 50	120	1200	17-25	120	60	38	750	125	0.7-1.2 t
DMS 95	240	1200	27-40	120	95	45	1000	130	1.2-1.8 t
DMS 165	310	1200	30-45	120	150	55	1050	165	1.8-3 t
DMS 210	500	1200	40-55	120	210	62	1200	190	2.8-3.8 t
DMS 300	700	1100	50-70	120	300	72	1435	205	4.0-6.0 t
DMS 400	900	900	70-95	120	400	80	1455	250	5.0-8.5 t
DMS 980	1600	900	100-130	130	950	102	1830	280	10-14 t

TRIVELLE E PINZE IDRAULICHE



CARATTERISTICHE:

Trivelle e pinze idrauliche per escavatori



Trivella TR 100

Pinza GMR 1300

MODELLO	PESO Kg	PRESSIONE Bar	Ø mm	INSTALLABILE su escavatore
TR 100	53	225	250	1,8 t
T 5	85	250	300	5 t
PINZA GMR 1300 HD	118	200	1400	4 / 5 t

MINIPALE GOMMATE

MOD. 226B3 HF

MINIPALE GOMMATE

MOD. 226B3 HF



CARATTERISTICHE:

Minipala gommata Caterpillar, comandi servoassistiti con joystick, acceleratore a pedale



MODELLO	PESO QI	POTENZA Hp	ALT. MAX. SOLL. mm	LARGHEZZA mm	CARICO OP. Kg
226B3 HF	26,4	62	2854	1525	680

+ ACCESSORI

Spazzatrice



Fresa autolivellante PL 50.20



Benna miscelatrice



Forche pallets

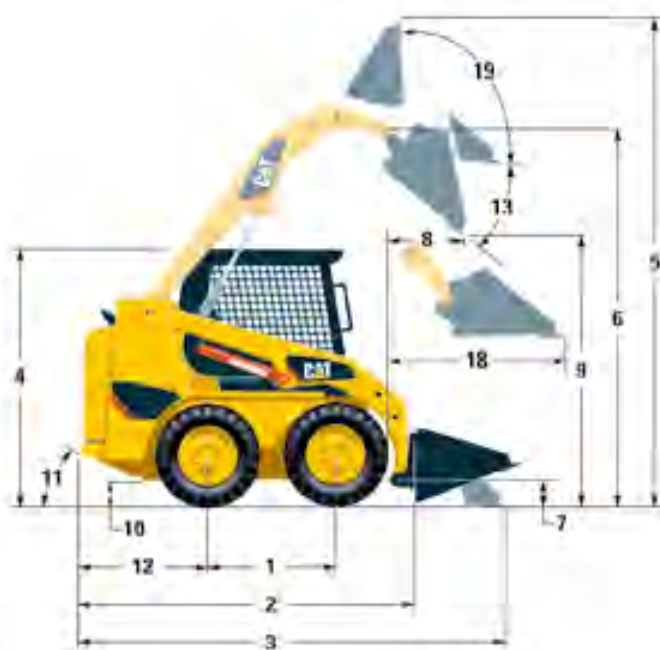

SCHEDA TECNICA 226B3 HF

1	Passo	986 mm
2	Lunghezza con benna a terra	3233 mm
3	Lunghezza senza benna	2519 mm
4	Altezza alla cabina	1950 mm
5	Altezza massima	3709 mm
6	Altezza massima al perno	2854 mm
7	Alt. al perno in posizione di trasporto	239 mm
8	Sbraccio alla mass. altezza	505 mm
9	Luce di scarico alla mass. alt. e ang.	2169 mm
10	Luce libera da terra	195 mm
11	Angolo di attacco	26°
12	Sbalzo posteriore	967 mm
13	Angolo massimo di scarico	40°

SCHEDA TECNICA 226B3 HF

14	Largh. mass. ai pneumatici	1525 mm
15	Raggio di curvatura sx	1485 mm
16	Raggio di curvatura dx	1199 mm
17	Raggio di curvatura massimo	1940 mm
18	Sbraccio con bracci e benna orizz.	1280 mm
19	Ang. di chiusura benna alla mass. alt.	97°



Sgancio rapido



HF impianto idraulico High Flow, alto flusso. Portata olio Lt/min 100.

MINIPALE CINGOLATE

MOD. 239D HF



CARATTERISTICHE:
Computer di bordo **ADVANCED** a display LCD per assistenza alla fresatura. Telecamera post.



+ ACCESSORI



Benna miscelatrice



Fresa autolivellante PL 50.20



Spazzatrice



Forche pallets



MODELLO	PESO QI	POTENZA Hp	ALT. MAX. SOLL. mm	LARGHEZZA mm	CARICO OP. Kg
239D HF	33	67	2825	1676	930

SCHEDA TECNICA 239D HF mm

1	Lunghezza cingolo al suolo	1384
2	Lunghezza cingolo	1808
3	Lunghezza senza benna	2522
4	Lunghezza con benna a terra	3234
5	Altezza alla cabina	2034
6	Altezza massima	3645
7	Altezza massima al perno	2825
8	Alt. al perno in posiz. di trasporto	218
9	Sbraccio alla mass. alt. di scarico	563
10	Luce libera alla mass. alt. di scarico	2057
11	Luce libera da terra	195
12	Angolo di attacco	34,5°
13	Angolo massimo di scarico	50,3°
14	Larghezza	1676

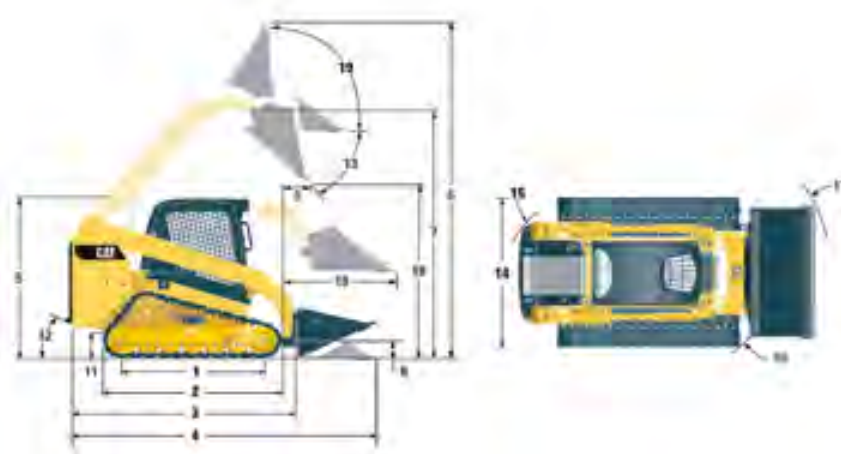

15	R. sterz. dal centro - posteriore	1458
16	R. sterz. dal centro - att. rapido	1159
17	R. sterz. dal centro - benna	2069
18	Sbraccio mass. con bracci orizz.	1356
19	Ang. di chiusura benna alla mass. alt. 85,5°	



Nuovo Carro Heavy Duty

MINIPALE CINGOLATE

MOD. 259D HFVL



CARATTERISTICHE:
Computer di bordo **ADVANCED** a display LCD per assistenza alla fresatura. Telecamera post.



+ ACCESSORI



Benna miscelatrice



Fresa autolivellante PL 50.20



Spazzatrice



Forche pallets



MODELLO	PESO QI	POTENZA Hp	ALT. MAX. SOLL. mm	LARGHEZZA mm	CARICO OP. Kg
259D HFVL	40	74,3	3075	1755	1315

SCHEDA TECNICA 259D HFVL mm

1	Lunghezza cingolo al suolo	1499
2	Lunghezza cingolo	1999
3	Lunghezza senza benna	2767
4	Lunghezza con benna a terra	3486
5	Altezza alla cabina	2111
6	Altezza massima	3915
7	Altezza massima al perno	3075
8	Alt. al perno in posiz. di trasporto	198
9	Sbraccio alla mass. alt. di scarico	608
10	Luce libera alla mass. alt. di scarico	2283
11	Luce libera da terra	226
12	Angolo di attacco	35°
13	Angolo massimo di scarico	52°
14	Larghezza	1755

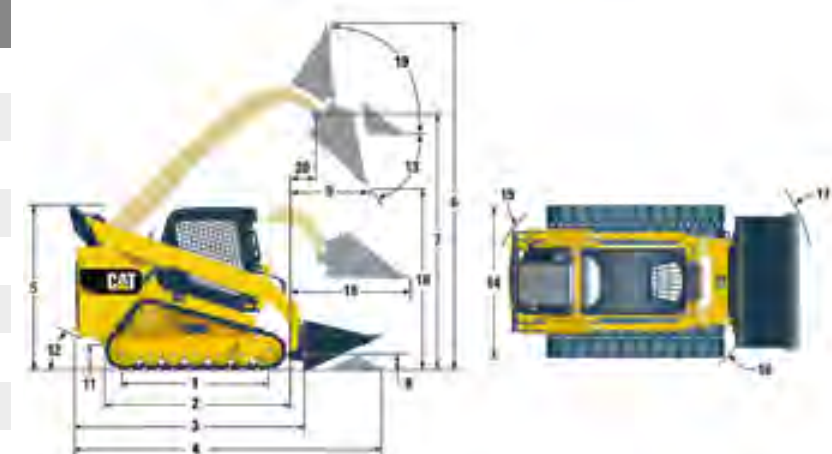

15	R. sterz. dal centro - posteriore	1561
16	R. sterz. dal centro - att. rapido	1392
17	R. sterz. dal centro - benna	2184
18	Sbraccio mass. con bracci orizz.	1305
19	Ang. di chiusura benna alla mass. alt. 87°	



Nuovo Carro Heavy Duty

MINIPALE CINGOLATE - ALTO FLUSSO

MOD. 289D XPSVL

MINIPALE CINGOLATE MOD. 289D XPSVLHF



CARATTERISTICHE:

Computer di bordo **ADVANCED** a display LCD per assistenza alla fresatura. Telecamera post.



+ ACCESSORI

Fresa autolivellante
PL 50.20 + PL 1000



Benna miscelatrice



Spazzatrice



Forche pallets



MODELLO	PESO QI	POTENZA Hp	ALT. MAX. SOLL. mm	LARGHEZZA mm	CARICO OP. Kg
289D XPS VL	47,78	74,3	3178	1981	1724

SCHEDA TECNICA 289D XPSVL mm

1	Lunghezza cingolo al suolo	1630
2	Lunghezza cingolo	2129
3	Lunghezza senza benna	2995
4	Lunghezza con benna a terra	3714
5	Altezza alla cabina	2113
6	Altezza massima	4051
7	Altezza massima al perno	3078
8	Alt. al perno in posiz. di trasporto	190
9	Sbraccio alla mass. alt. di scarico	761
10	Luce libera alla mass. alt. di scarico	2387
11	Luce libera da terra	226
12	Angolo di attacco	33°
13	Angolo massimo di scarico	51°
14	Larghezza	1981

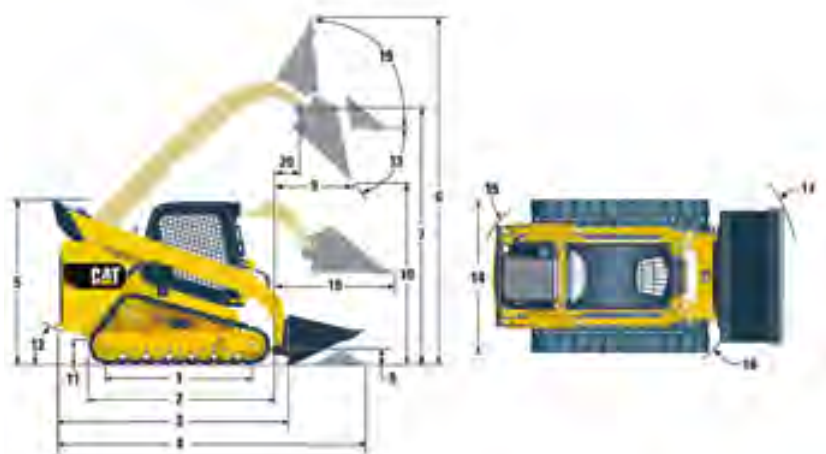

15	R. sterz. dal centro - posteriore	1796
16	R. sterz. dal centro - att. rapido	1410
17	R. sterz. dal centro - benna	2256
18	Sbraccio mass. con bracci orizz.	1270
19	Ang. di chiusura benna alla mass. alt. 84°	



Nuovo Carro Heavy Duty



CARATTERISTICHE:

Modello 289D XPSVL con sistema lama livellatrice idraulica LL2016, completa di sensori laser



SCHEDA TECNICA LL2016

1	Lunghezza	2400 mm
2	Altezza max	960 mm
3	Altezza lama	725 mm
4	Larghezza max	1000 mm
5	Larghezza	785 mm
6	Portata olio	45 L/min
7	Pressione olio	220 bar



Lama livellatrice



CARATTERISTICHE:

Modello 289D XPSVL con escavatrice a ruota T600



SCHEDA TECNICA LL2016

1	Larghezza	80 mm
2	Prof. scavo	200-600 mm
3	Portata olio	90-160 L/min
4	Pressione olio	300-160 bar
5	Peso	1260 kg



Escavatrice a ruota T600

FRESATRICI AUTOLIVELLANTI

ACCESSORI MINIPALE

SIMEX
HEAVY MADE EASY

CARATTERISTICHE:

Serbatoio acqua integrato su fresa. Fresatrici ad alto flusso



SCHEMA TECNICA	PL 50.20	PL 1000
Larghezza	500	1000
Profondità	0-170	0-130
Denti tamburo asfalto	52	78
Angolo di autolivellamento	30°	30°
Velocità media di lavoro (tamburo base 50% di prof.)	80-400	80-400
Regolazione di profondità	dx e sx indipendenti	meccanica
Traslazione laterale	idraulica	idraulica
Spostamento	650-(1250)	650-(1250)
Min. distanza dal marciapiede	65-(30)	65-(30)
Angolazione trasversale	automatica	automatica
Inclinazione	16°	16°
Peso operativo	900-1050	1090-1200
Portata olio richiesta	90-160	95-200
Pressione richiesta	300-160	350-180



ESCAVATRICE A RUOTA T600

SIMEX
HEAVY MADE EASY

CARATTERISTICHE:

Progettate per scavi a sezione predefinita su superfici dure e compatte - anche per fibra ottica



MODELLO	LARGHEZZA mm	PROF. SCAVO mm	PORTATA OLIO L/min	PRESSIONE OLIO bar	PESO Kg
T600	80	200-600	90-160	300-160	1260

LAMA LIVELLATRICE

CAT Rental

CARATTERISTICHE:

Lama livellatrice idraulica con sensori laser



MODELLO	LUNGHEZZA mm	LARGH. UTILE mm	ALTEZZA mm	PORTATA OLIO L/min
LL2016	2400	785	725	45

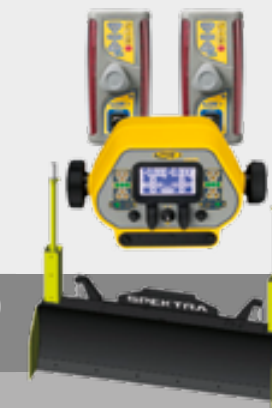

BENNE SPAZZATRICI

CANGINI

CARATTERISTICHE:

Benna spazzatrice



MODELLO	LARGHEZZA mm	LARGH. UTILE mm	CAPACITÀ Lt	PESO Kg
SPZ180	1950	1800	490	360



BENNE MISCELATRICI

CANGINI

CARATTERISTICHE:

Benne Miscelatrici



MODELLO	LARGHEZZA mm	CAPACITÀ Lt	MOTORE cc	PESO Kg
Condor 250 HD	1480	280	250	290



FORCHE

CANGINI

CARATTERISTICHE:

Forche per Minipale Cat 226 - 239 - 259 - 279 - 289



PESO Kg	PORTATA Kg	LUNGHEZZA FORCHE cm
250	1000 / 1200	1000 / 1200



VIBROCOSTIPATORI VERTICALI

MOD. BS 60-2 I



CARATTERISTICHE:

Miscelazione automatica, avviamento manuale



MODELLO	PESO Kg	N. VIBRAZIONI Min	LARGHEZZA mm	MOTORE ALIM.
BS 60-2 i	66	700	280	Miscela 2t

PIASTRE VIBRANTI

MOD. WP 1235 A / WP 1550 AW



CARATTERISTICHE:

Con serbatoio d'acqua, avviamento manuale, per asfalto e betonelle



MODELLO	PESO Kg	FORZA CENTRIFUGA kN	LARGHEZZA mm	MOTORE ALIM.
WP 1235 A	76	12	350	Honda 4t
WP 1550 AW	88	15	500	Honda 4t

PIASTRE VIBR. REVERSIBILE MOD. DPU 2550 H / 3070 H



CARATTERISTICHE:

Avviamento manuale



MODELLO	PESO Kg	FORZA CENTRIFUGA kN	LARGHEZZA mm	MOTORE ALIM.
DPU 2550 H	154	25	760	Hatz diesel
DPU 3070 H	187	30	700	Hatz diesel

PIASTRE VIBR. REV. MOD. DPU 4045 YE / 5045 H / 6055 H



CARATTERISTICHE:

Avviamento elettrico



MODELLO	PESO Kg	FORZA CENTRIFUGA kN	LARGHEZZA mm	MOTORE ALIM.
DPU 4045 YE	322-368	40	600	Yanmar Diesel
DPU 5045 H	410	50	610	Hatz diesel
DPU 6055 H	454	60	710	Hatz diesel

RULLI VIBRANTI FILO MURO

MOD. CB-113



CARATTERISTICHE:
Tamburo filo muro



MODELLO	PESO QI	LARGHEZZA mm	POTENZA Hp	FREQUENZA Hz	VIBRAZIONE
CB-113	15	940	20	53,3	Posteriore

SCHEDA TECNICA	mm
A Lunghezza	2080
B Passo	1430
C Diametro tamburo	575
D Spessore mantello	10
E Altezza volante	1522
F Altezza al ROPS (luce rotativa)	2624
G Altezza al ROPS ripiegato	1735
H Luce libera	195
J Larghezza compattazione	880
I Larghezza macchina	940

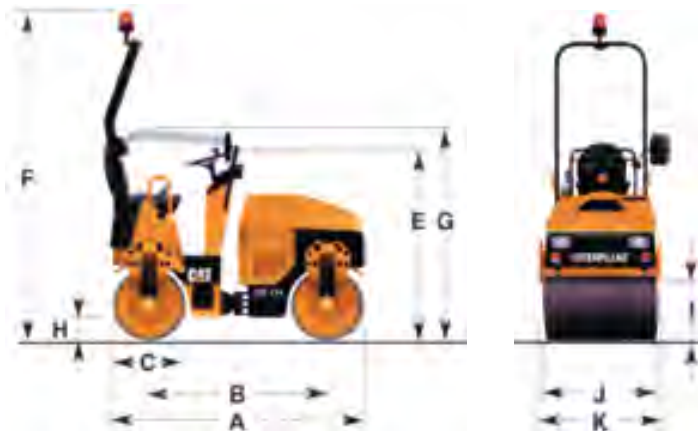

RULLI VIBRANTI

MOD. CB 224 / CB 24B



CARATTERISTICHE:
Rullo vibrante Caterpillar



MODELLO	PESO QI	LARGHEZZA mm	POTENZA Hp	VIBRAZIONE
CB 224	26,3	1300	32,7	Combinata
CB 24B	27,2	1312	33	Combinata

SCHEDA TECNICA	CB 224	CB 24B
A Lunghezza	2430 mm	2575 mm
B Passo	1730 mm	1800 mm
C Diametro tamburo	700 mm	720 mm
D Spessore mantello	13,5 mm	13,5 mm
E Altezza volante	1807 mm	1807 mm
F Altezza al ROPS	2589 mm	2700 mm
G Luce libera da terra	254 mm	285 mm
H Luce libera laterale	519 mm	500 mm
J Larghezza compattaz.	1200 mm	1200 mm
I Larghezza macchina	1300 mm	1312 mm



DUMPER

MOD. D150 AHG



CARATTERISTICHE:
Dumper idrostatico AUSA



MODELLO	PESO QI	PORTATA Kg	LARGHEZZA mm	MOTORE ALIM.
D150 AHG	15	1500	1450	Diesel

DUMPER

MOD. FIORI DF25



CARATTERISTICHE:
Dumper idrostatico Fiori, scarico trilaterale



MODELLO	PESO QI	PORTATA Kg	LARGHEZZA mm	MOTORE ALIM.
DF25	20	2000	1580	Diesel

MOTOCARRIOLE

MOD. HS 1100 / R 100 / DTO 8



CARATTERISTICHE:

Motocarro e Mini Dumper. Carro allargabile



MODELLO	PESO Kg	PORTATA Kg	LARGHEZZA NASTRO mm	MOTORE ALIM.
R 100	420	850	800	Benzina 4t
DTO 8	520	800	800	Benzina 4t
HS 1100	760	1100	758 / 1058	Benzina 4t

NASTRI TRASPORTATORI



Una nuova edilizia

CARATTERISTICHE:

Struttura in alluminio



MODELLO	PESO Kg	LUNGHEZZA NASTRO mt	LARGHEZZA NASTRO mm	MOTORE ALIM.
N / C.F. System	70 / 80	3 / 4	400	Elettrica 220

SOLLEVATORI TELESCOPICI

MOD. APOLLO 25.6



CARATTERISTICHE:
Sollevatore telescopico Dieci



MODELLO	PESO Ql	POTENZA Hp	ALT. SOLL. mm	SBRACCIO m	PORTATA MAX Kg
APOLLO 25.6	48	50,7	5,78	3,25	2500

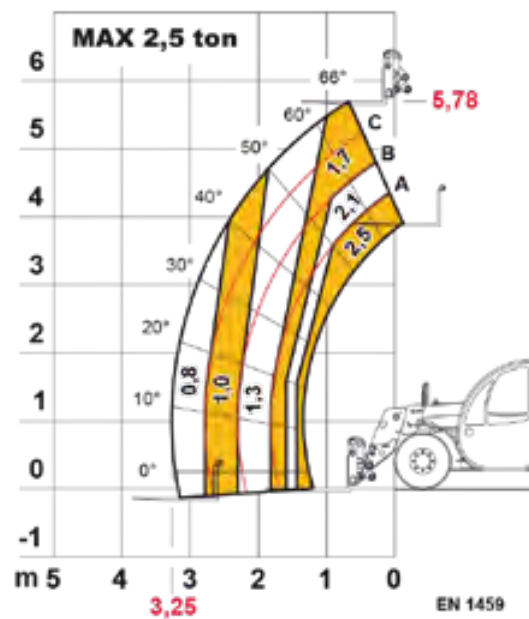

APOLLO 25.6

SOLL. TELESCOPICI GIREVOLI

MOD. PEGASUS 38.16



CARATTERISTICHE:
Sollevatore telescopico girevole Dieci



MODELLO	PESO Ql a vuoto	POTENZA Kw	ALT. SOLL.	SBRACCIO m	PORTATA MAX Kg
Pegasus 38.16	132	101	15,5	13,8	3800

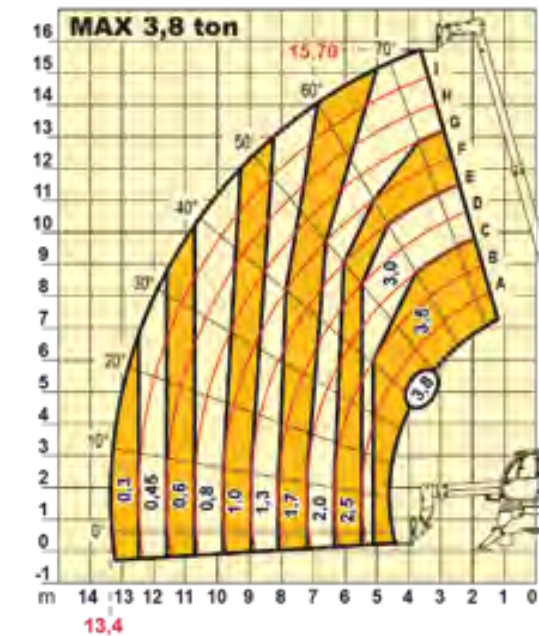

PEGASUS 38.16 400°

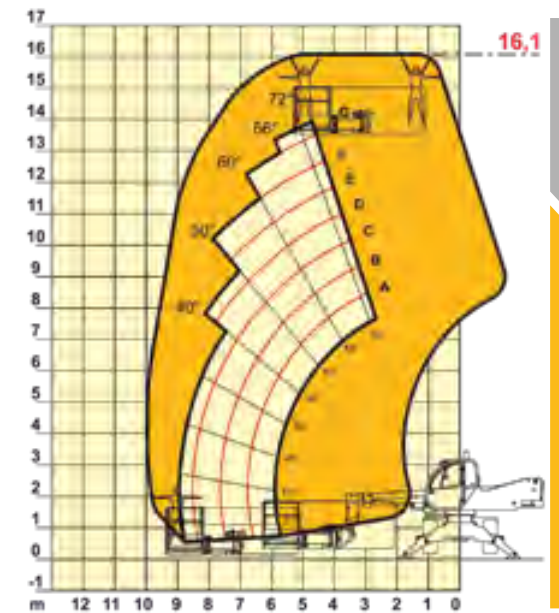

PEGASUS 38.16 400°

SOLL. TELESCOPICI GIREVOLI

MOD. PEGASUS 40.18



CARATTERISTICHE:

Sollevatore telescopico girevole, con radiocomando



MODELLO	PESO Ql a vuoto	POTENZA Hp	ALT. SOLL.	SBRACCIO m	PORTATA MAX Kg
40.18	137	101 Kw	18 m	15,3	4000

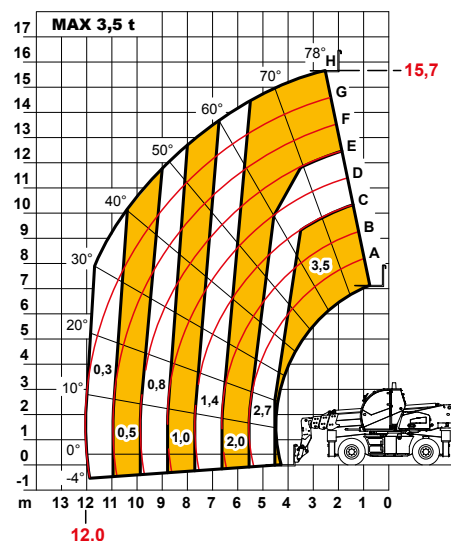
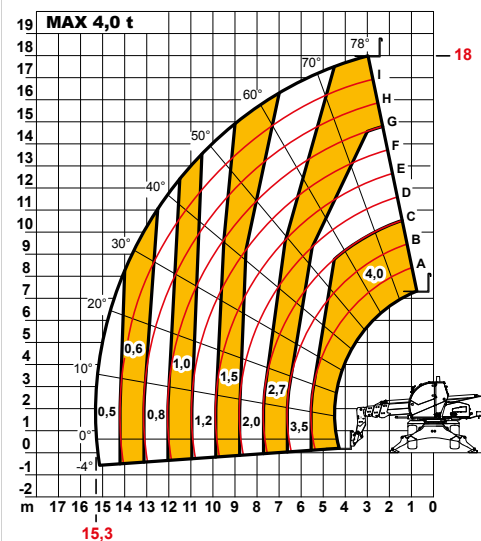

BENNA PER APOLLO

ACCESSORI TELESCOPICI

CARATTERISTICHE:

Benna

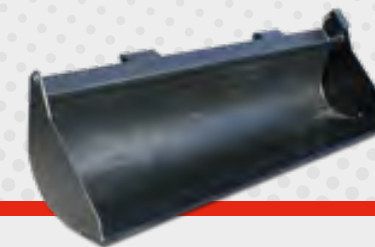

CESTA PORTA PERSONA

CARATTERISTICHE:

Cesta porta persone trilaterale



MODELLO	ESTENSIBILE Mt	PORTATA MAX Kg
Cesta porta pers.	2,40 / 4,20	300

GANCIO

CARATTERISTICHE:

Gancio portata massima ton. 3,8

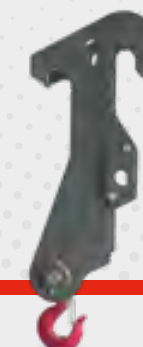

FALCONE VERRICELLO

CARATTERISTICHE:

Falcone Verricello



MODELLO	LUNGHEZZA Mt	PORTATA MAX t
Falcone verricello	2,5	1,2

RADIOCOMANDO

CARATTERISTICHE:

Radiocomando AUTECH per PEGASUS 40.18





GRU EDILI



PIATTAFORME AEREE

GRU EDILI

MOD. MONOFASE E TRIFASE



CARATTERISTICHE:

Gru edili a montaggio automatico



MODELLO	SBRACCIO mt	ALTEZZA mt	PORTATA MAX Kg	PORTATA PUNTA Kg
B14	14	12	800	400
IGO 11	18	16	1300	650
OMV 260	16	15	1600	600
OMV 330	18	16,5	1200	700
OMV 331	20	16,8	1800	700
OMV 293	22	18	1800	750
B824	24	18	1600	800
OMV 280	25	18,5	1800	750
OMV 360	25	22	2200	800
IGO 21	24	18	1600	750
B826	26	18,5	1600	800
OMV 350	27	23	2200	850



EXTRA: Consulenza tecnica-commerciale specializzata presso vostro cantiere

GRU EDILI

MOD. TRIFASE



CARATTERISTICHE:

Gru edili a montaggio automatico



MODELLO	SBRACCIO mt	ALTEZZA mt	PORTATA MAX Kg	PORTATA PUNTA Kg
E 2610HD	28	18,5	2000	800
OMV 312	30	20,5	3000	1000
OMV 30A	30	22,7	3000	1000
HUP 32-37	32	27	4000	1000
OMV 320	33	21,5	3000	1000
OMV 300	36	22	3000	1000
OMV 34A	34	24	4000	1000
OMV 370	38	24,5	3000	1000
OMV 40A	40	22,5	4000	1400
OMV 340	41,8	24,7	3000	1000



EXTRA: Assistenza tecnica in cantiere

GIURIATO
Una nuova edilizia

CARATTERISTICHE:
Gru edili a montaggio automatico



MODELLO	SBRACCIO m	ALTEZZA m	PORTATA MAX Kg	PORTATA PUNTA mm
MR 45 E	42	36	2500	1000
MTC 68	46	39	2500	1100
MRT 69	45	36	2500	1250
MTC 78	51	36,9	3000	1000
MR 75 E	48	40	4000	1300
MR 81	51	40,5	4000	1000
MRT 84	51	40	2500	1250
MR 99	58	46,6	6000	1200
MRT 99+3	60	47	6000	1150

+ ACCESSORI:

Quadro elettrico da cantiere



Forca



Benna conica e autoscaricante



TRASPORTO

MONTAGGIO

ASSISTENZA

VERIFICHE TRIMESTRALI VENTENNALI

ATTREZZI COLLEGATI A NOLEGGIO

RICAMBI



GRU PER LAVORI DI RESTAURO

GIURIATO
Una nuova edilizia

CARATTERISTICHE:
Gru per lavori di restauro, centri storici "CS" trifase



MOD. CS TRIFASE

+ ACCESSORI:

Forca



Benna autoscaricante



Benna conica



SOLLEVATORI MULTIFUNZIONE

GIURIATO
Una nuova edilizia

CARATTERISTICHE:
Sollevatori multifunzione monofase



MOD. MONOFASE

+ ACCESSORI:

Forca



Benna autoscaricante



Benna conica



MODELLO	SBARCCIO m	ALTEZZA mm	PORTATA MAX Kg	PORTATA PUNTA Kg
CS 18	18	24	1300	-
CS 20	20	24	1300	400
CS 22	22	27	1300	400

MODELLO	SBARCCIO m	ALTEZZA mm	PORTATA MAX Kg	PORTATA PUNTA Kg
E 300M	3	16	300	150
K 800	5	19	800	200

BENNA CONICA

CARATTERISTICHE:
Scarico centrale laterale



ACCESSORI



BENNA AUTOSCARICANTE

CARATTERISTICHE:
Scarico centrale laterale



BENNA CONICA

CARATTERISTICHE:
Forca portata 15 /20 qli



QUADRO ELETTRICO

CARATTERISTICHE:
Quadro elettrico da cantiere



PIATTAFORME AUTOCARRATE



CARATTERISTICHE:

Piattaforme aeree su automezzi con patente B



SCHEDA TECNICA DA 20 DA 320 P200A

Altezza max lavoro			
Altezza piano calpestio			
Sbraccio max lavoro			
Rotazione torretta			
Portata max cestello			
Altezza in marcia			
Automezzo			
Larghezza			

Chilometraggio massimo percorribile 150/gg.
Oltre questo chilometraggio verranno addebitati 0,20 euro al Km.
Ore lavorative giornaliere max 8.

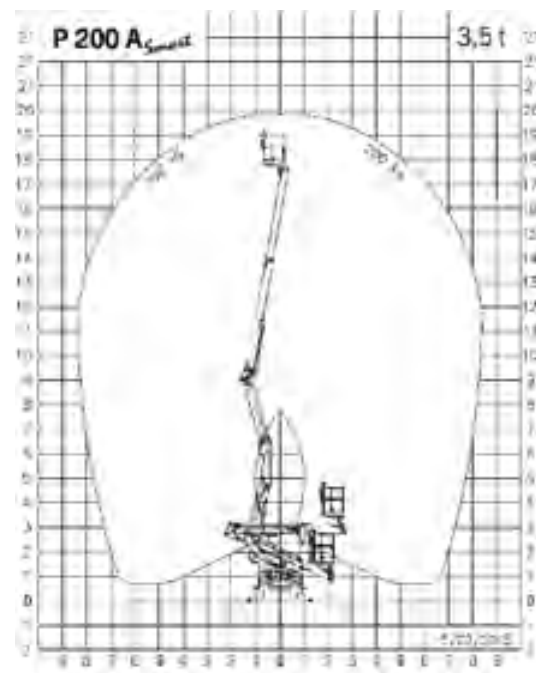

PIATTAFORME A PANTOGRAFO ELETTRICHE



CARATTERISTICHE:

Piattaforme aeree semoventi verticali elettriche



MODELLO	PESO QI	H PIANO CALP. m	LARGHEZZA m	LUNGHEZZA m	H CHIUSA m
Optium 8	13,7	5,8	0,76	1,90	2,0
Compact 10	21,6	8	0,81	2,48	2,17
GS 2632	19,46	8	0,81	2,26	2,26
GS 3246	28,12	10	1,15	2,26	2,39



PIATTAFORME AEREE

MOD. LIGHTLIFT 17.75



CARATTERISTICHE:

Portata 230 Kg su tutta l'area di lavoro. Pulsantiera a filo estensibile
Stabilizzazione automatica, motore elettrico supplementare (monofase per uso interno)

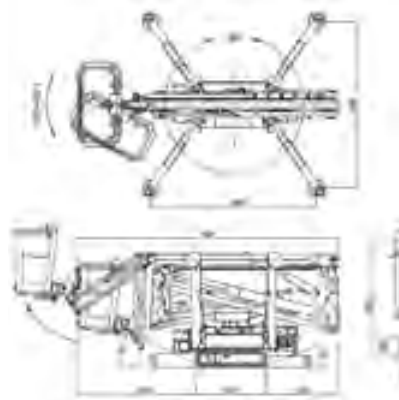
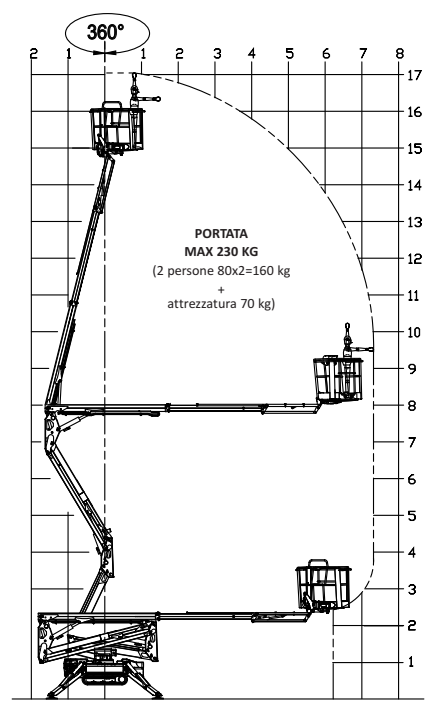

MODELLO	PESO Ql	POTENZA Hp	CINGOLI ALLARGABILI cm	MOTORE	PORTATA Kg	H PIANO CALP. m
Lightlift 17.75	23	11,7	7,98 / 1086	Benzina / Elettrico	230	15

PIATTAFORME AEREE

MOD. GOLDLIFT 14.70



CARATTERISTICHE:

Piattaforme aeree cingolate, cingoli in gomma pendenza superabile 33%
Motore elettrico supplementare (monofase per uso interno)

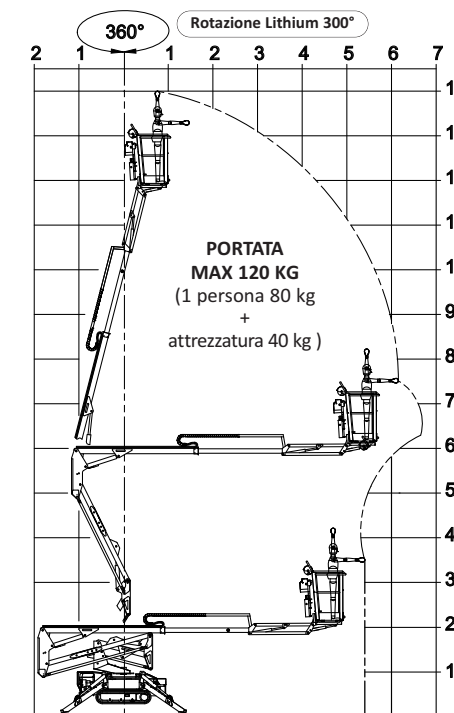

MODELLO	PESO Ql	POTENZA Hp	MOTORE	PORTATA Kg	H PIANO CALP. m
Goldlift 14.70	17	7	Benzina / Elettrico	120 / 200	Kg 220 max 10 Kg 120 max 12

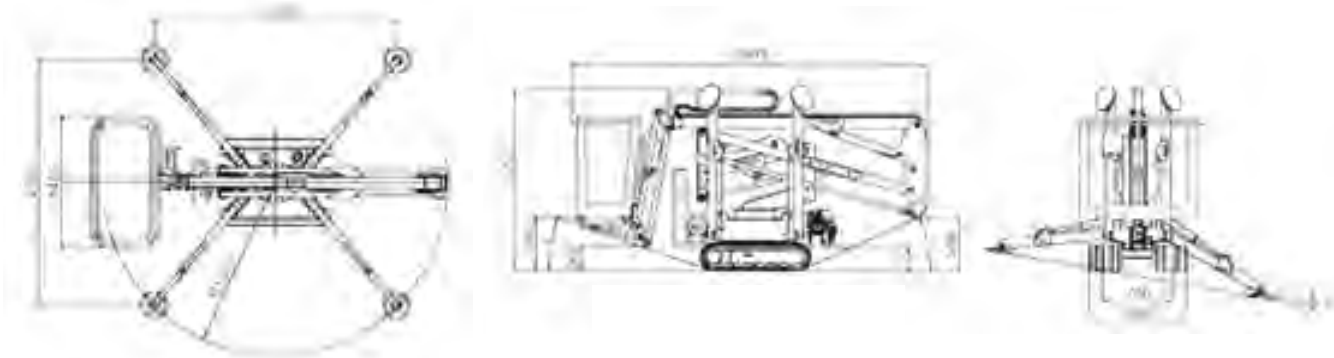



SISTEMI DI CASSERATURA



ARMAMENTO SOLAIO



PONTEGGI & TRABATELLI



CARATTERISTICHE:

Alluminio, facili da movimentare e montare



DIMENSIONE cm	MATERIALE	PESO Kg
300 x 200	Ferro	215
300 x 100	Alluminio	62
300 x 20 / 75	Alluminio	48
150 x 100	Alluminio	33
150 x 20 / 75	Alluminio	25

Per le offerte consultare il nostro responsabile tecnico-commerciale.

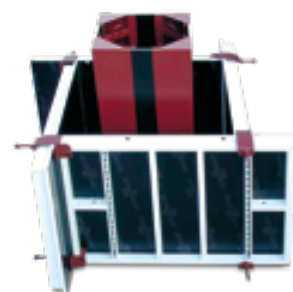

Bicchiera interna
(esclusi pannelli legno)
Peso 133 Kg

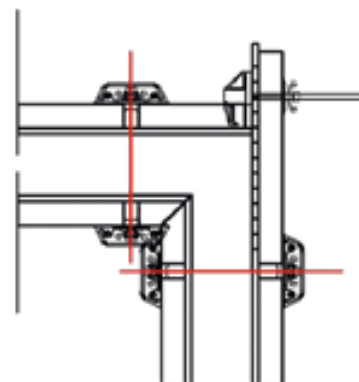

300 x 100 cm
Alluminio

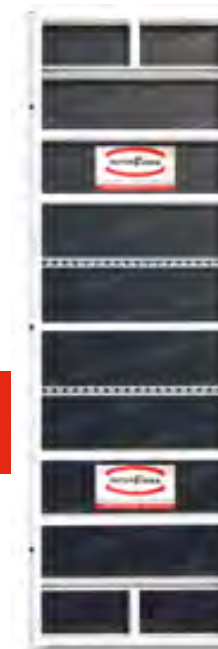

150 x 100 cm
Alluminio



**AMPIA GAMMA
DI ACCESSORI E
SOTTOMISURE
IN ALLUMINIO**

Altezza
da 300 a 150 cm

Larghezza
da 75 a 20 cm

CASSEFORME MAXIM ALU













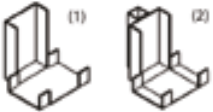



ACCESSORI

CASSEFORME MAXIM ALU ACCESSORI

CARATTERISTICHE: Accessori Maxim ALU InterFama



	Angolo interno 300 x 25 x 20 cm - Kg 53 150 x 25 x 20 cm - Kg 26		Morsetto parete Kg 4
	Angolo a cerniera 300 x 25 x 20 cm Kg 70		Morsetto allineatore Kg 7,5
	Angolo disarmo 300 x 25 x 25 cm Kg 85 150 x 25 x 25 cm Kg 57		Morsetto angolo esterno (completo di cunei) Kg 4,5
	Compenso 300 x 10 / 5 / 3 cm Kg 15		Morsetto regolabile Kg 5,7
	Compenso in lamiera 300 x 20 cm Kg 26		Morsetto angolo pilastro Kg 2,6
	Compenso in lamiera per angolo 300 x 15 cm Kg 25		Farfalla girevole norma UNI Kg 1,6
	Morsetto regolabile per circolare Kg 6		Tenditore zincato da 85 cm in su 150 / 175 cm 200 / 300 cm Kg 1,4
			Alfen 34 cm Kg 0,6

	Dado farfalla 50 mm Kg 0,3		Puntone sopralzo Kg 4
	Jolly maxim Kg 0,3		Mensola regolabile sopralzo Kg 12
	Morsetto per plinto Kg 3,9		Gancio Gru Kg 3,3
	Bicchiere interno plinto 300 x 10 / 5 / 3 cm Kg 22		Chiusura di testata Kg 3,3
	Mensola di servizio Kg 13		Allineatore snodato Kg 7
	Puntello 4,5 m con distanziale Kg 21,5 Puntello 6 m con distanziale Kg 33,5		Accessorio regolabile circolare Kg 8
	Kit trasporto Kg 11,4		Puntone triangolo per controterra Kg 90
	Kit di foratura		Base monofaccia per puntone triangolo 150 cm Kg 90



CARATTERISTICHE:

Sicurezza e versatilità. Montaggio rapido, disarmo anticipato. Carpenterie ridotte



FLESSIBILE

Permette di casserare ogni tipo di solaio: Getto pieno - Predalles - Laterocemento

Risparmio fino al 30%
su costi e tempi di posa.

GRIGLIA

ANTISCIVOLO

RAPIDO, SICURO E LEGGERO

Componenti leggeri
in alluminio con
montaggio rapido sia
dal piano superiore
che inferiore.

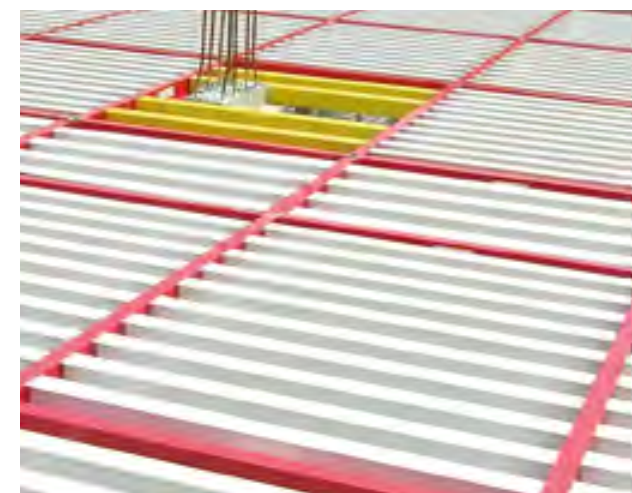

ECONOMICO

Ridotto numero di componenti per una
facile movimentazione e stoccaggio















FORTE

Con il puntello E35 consente la messa in
opera di solette fino a 30 cm di spessore

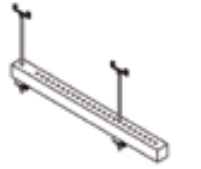

SISTEMI DI ARMAMENTO SOLAIO VELOX ACCESSORI

CARATTERISTICHE: Accessori Maximum ALU InterFama

	Trave portante Velox 100 cm - Kg 7,7 150 cm - Kg 11,56 200 cm - Kg 15,18		Prolunga per puntello EN1065 100 cm Kg 6
	Testa a caduta Velox incl. 2 viti per fissaggio Kg 5,5		Trepiede per puntello EN1065 zincato Kg 10,6
	Griglia ALU 150 x 100 cm superficie antiscivolo Kg 10		Distanziatore puntelli 150 / 200 cm Kg 11,7
	Griglia ALU 200 x 50 cm superficie antiscivolo Kg 7,63		Telaietto Velox 150 cm - Kg 14,5 200 cm - Kg 18,3
	Travetto lamellare 7 x 10 x 192 cm		Accessorio per fissaggio puntello al muro Kg 0,6
	Accessorio porta trave ribassata 10 x 10 x 142 cm compl. Kg 9,9		Accessorio per fissaggio puntello al muro 0 - 50 cm Kg 3,1
	Puntello EN 1065 E35 205 / 350 cm Kg 28		Attacco semplice diametro 76 / 48 mm Kg 1,9
			Elemento di collegamento trave universale Kg 1,4

SISTEMI DI ARMAMENTO SOLAIO VELOX ACCESSORI

	Spinotto per trave portante Velox 200 cm Kg 0,8		Puntone parapetto Kg 2,5
	Supporto scorrevole Kg 3,3		Contenitore Zincato 120 x 125 x 120 cm
	Spondina fermagetto per trave portante Velox Kg 7,1		Pannello giallo a 3 strati 200 x 50 x 2,7 cm Kg 12,5

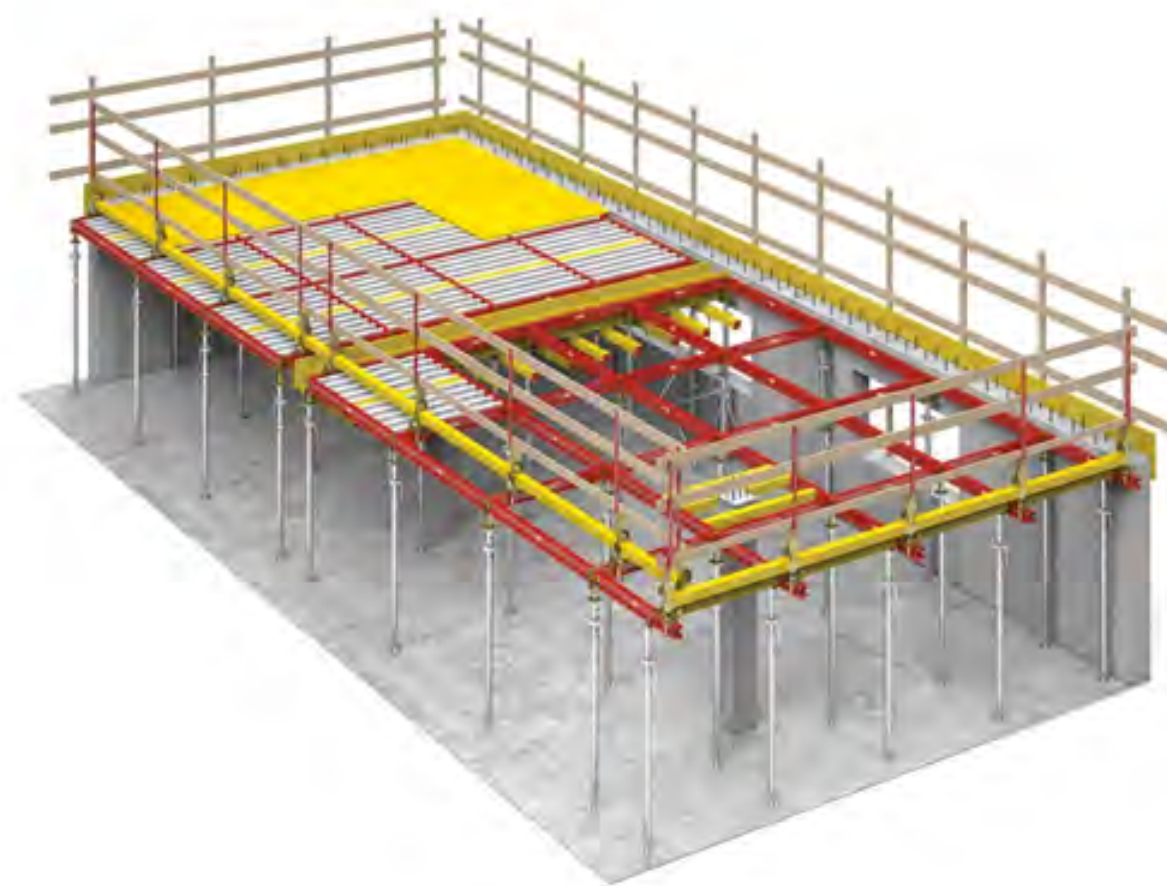

VELOX, è il sistema di cassetta universale per solai. Universale in quanto permette di armare e successivamente disarmare anticipatamente ogni tipo di solaio sia esso getto pieno, a lastre prefabbricate o alleggerito.



CARATTERISTICHE:

Cassaforma per il getto di pareti curvilinee, serbatoi o vasche circolari, composta da elementi prefabbricati pronti all'uso



MODELLO	ALTEZZA mt	LUNGHEZZA mt	ACCESSORI DI BASE	DIMA IN LEGNO
Orbis	H 150 - 200 - 300	1,00 - 1,10	Morsetto parete - regolabile	A carico cliente

CARATTERISTICHE E VANTAGGI

- Solo due elementi (110 e 100 cm)
- Collegamenti facili e veloci
- Due varianti di utilizzo *
- Regolazione raggio da 3,0 m all'infinito
- Imballo semplice e veloce
- Trasporto facilitato con l'apposito KIT
- Abbinabile ai sistemi di casseforme rettilinee
- Accoppiamento orizzontale e verticale con un semplice colpo di martello
- Chiusura del cerchio senza elementi speciali

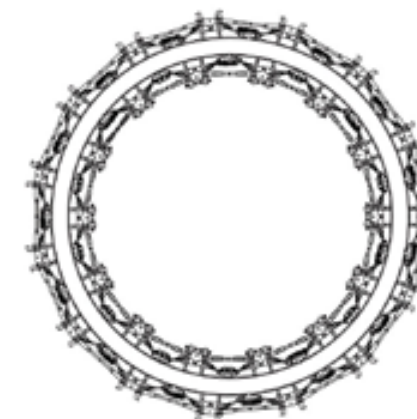

* SENZA TIRANTI PASSANTI

Questa variante permette l'esecuzione di manufatti con raggio compreso tra un minimo di 3 mt ed un massimo di 20 mt.



* CON TIRANTI PASSANTI

La variante con tiranti passanti consente completamente di realizzare pareti circolari o curvilinee, a partire da un raggio minimo di 3 mt sino all'infinito.



PONTEGGI PREFABBRICATI

MOD. PRATICO 70



CARATTERISTICHE:

Telaio "H" Pratico 70 zincato e Parapetto di sicurezza



IL PONTEGGIO FACILE

Da sempre a fianco delle imprese edili con esperienza e professionalità.

I servizi offerti vanno dalla vendita, noleggio e consulenza per le macchine e le attrezzature edili alla valutazione, progettazione, noleggio e montaggio di ponteggi.

Un servizio che permette all'impresa di avere tecnici specializzati, direttamente sul cantiere.

Tecnici che, con l'ausilio di materiali e marchi leader nel settore, costruiranno il cantiere in modo sicuro, professionale funzionale alle esigenze dell'impresa.

I NOSTRI SERVIZI

Consulenza progettazione, noleggio e montaggio di ponteggi con servizio di rilievo in cantiere.

Disegno esecutivo

Relazione di calcolo con ingegnere

POS piani operativi di sicurezza

PIMUS

PER INFORMAZIONI E PRENOTAZIONI

• **SEDE:** via M. Summano, 101 - 36010 Zanè (VI)
t. +39 0445 315700 - info@giuriato.it
www.giuriato.it

• **FILIALE:** via Olmo, 41 S.R.11 - 36077 Altavilla Vic.na (VI)
t. +39 0444 522880 - info.altavilla@giuriato.it
www.giuriatostore.com

PONTEGGI TELAIO PRATICO 70

CARATTERISTICHE:

Accessori per Telaio Pratico 70



ACCESSORI



Telaio Pratico 70
70 x 200 cm
Kg 18



Telaietto di parapetto
180 cm
Kg 12,4



Corrente Passo 180
Kg 2,78
Diagonale Passo 180
Kg 3,1



Tavola CK
180 x 33 cm
Kg 11,71



Tavola con Botola
50 x 180 cm - Kg 21,5
Scala per botola
203 x 38 cm - Kg 6,35



Fermapiede metallico
180 cm
Kg 4,67



Telaietto di testata PH 70
70 cm
Kg 6,5



CARATTERISTICHE:

Telaio Rapido RP 105 zincato e Telaio ridotto RP 105 zincato



PONTEGGI RAPIDO RP 105

ACCESSORI

















CARATTERISTICHE:

Accessori per Telaio Rapido RP 105 zincato



 <p>Telaio Rapido 105 105 x 200 cm Kg 21,2</p>	 <p>Telaio ridotto Rapido 105 105 x 120 cm Kg 15,3</p>
 <p>Corrente Passo 180 Kg 2,78 Diagonale Passo 180 Kg 3,1</p>	 <p>Portatelaio PZ 40 213 x 117 cm Kg 76,7</p>

PONTEGGI RAPIDO RP 105 ACCESSORI

 <p>Tavola a profilo chiuso CK 180 x 0,5 cm Kg 15,83</p>	 <p>Tavola con Botola 50 x 180 cm - Kg 21,5 Scala per botola 203 x 38 cm - Kg 6,35</p>
 <p>Fermapiede metallico 180 cm Kg 4,67</p>	 <p>Telaietto di testata universale 105 cm Kg 8</p>
 <p>Aste di parapetto integrata 110 cm Kg 6,7</p>	 <p>Montante 12 boccole 200 cm - Kg 8 Rinforzo per montante 12 boccole 185 cm - Kg 9,5</p>
 <p>Telaio inferiore per partenza stretta 40 x 200 cm Kg 18,7</p>	 <p>Telaio superiore per partenza stretta 40 x 200 cm Kg 27,8</p>
 <p>Mensola Universale 50 cm - Kg 6,2 70 cm - Kg 8,95 105 cm - Kg 11,5</p>	 <p>Mensola Interna 33 33 cm Kg 2,7</p>
 <p>Trave carraia 360 cm - Kg 27,1 540 cm - Kg 43,1</p>	 <p>Telaio di partenza sottopasso 175 x 241 cm Kg 32</p>
 <p>Basette regolabili 25 cm - Kg 2,5 45 cm - Kg 3,7 75 cm - Kg 4,85 Basette fisse Kg 1,05</p>	 <p>Parasassi integrato universale Kg 16,2</p>
 <p>Barra di ancoraggio 40 / 70 cm Kg 1,7 / 2,85</p>	 <p>Tubo da 0,5 a 6 mt Spinotto Kg 0,64 Giunto Kg 1,3</p>

PONTEGGI DI FACCIATA IN ALLUMINIO

MOD. P.L.A.



CARATTERISTICHE:

Ponteggi di facciata in alluminio leggero, facile nel montaggio



PONTEGGI ALLUMINIO MOD. P.L.A.















ACCESSORI

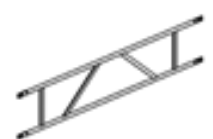

CARATTERISTICHE:

Per strutture di varie dimensioni e altezze con possibilità di configurazioni mobili su ruote



	Telaio in alluminio 80 x 200 cm - Kg 8,5 80 x 150 cm - Kg 7 80 x 100 cm - Kg 5,8		Parapetto laterale per mensola con fermapiede 80 x 120 cm - Kg 5,3
	Elemento di sommità 80 x 120 cm Kg 3		Parapetto laterale di sommità con fermapiede 80 x 120 cm - Kg 6
	Elemento terminale per mensola 80 x 120 cm Kg 3		Stabilizzatore 150 x 250 cm Kg 10
	Parapetto doppio in alluminio 250 x 50 cm Kg 6		Tavola in acciaio zincato 250 x 31 cm Kg 15
	Corrente in alluminio Passo 250 - Kg 2,4 Diagonale di facciata Passo 250 - Kg 3		Botola con scala in alluminio 250 x 62 cm Kg 25,4
	Corrente di partenza Passo 250 - Kg 6,3 Diagonale di partenza Passo 250 - Kg 7,7		Basetta fissa e regolabile 50 cm - Kg 3
	Fermapiede in acciaio 250 x 20 cm Kg 7		Staffa con gancio diametro 48 60 cm Kg 2,5

TRABATTELLI ALLUMINIO / ALUMITO MAXI



CARATTERISTICHE:

Dimensioni contenute, facile da montare, indicato per interni industriali / commerciali

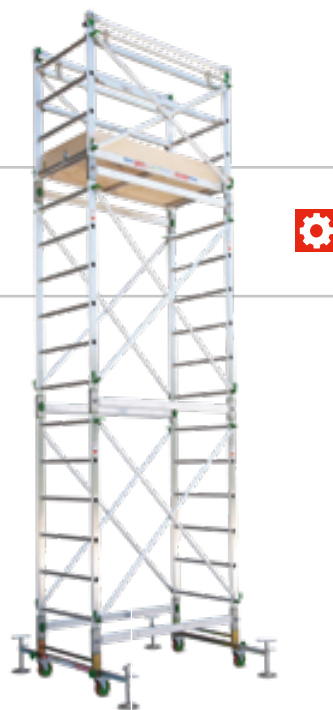

MODELLO	BASE Cm	PIANO LAVORO Cm	PIANO CALP. H Max m	PORTATA Kg
Alumito	86 x 160	68 x 150	4,2	150

TRABATTELLI ALLUMINIO / CAPO - 1



CARATTERISTICHE:

Dimensioni contenute, montaggio rapidissimo con congiunzioni ad aggancio automatico, indicato per lavori edili, impiantistica e decorazioni



MODELLO	BASE Cm	PIANO LAVORO Cm	PIANO CALP. H Max m	PORTATA Kg
Capo / 1	77 x 161	60 x 143	6,5	180

TRABATTELLI ALLUMINIO / DOGE 65



CARATTERISTICHE:

Grande solidità e fermezza, professionale e rapido nel montaggio



MODELLO	BASE Cm	PIANO LAVORO Cm	PIANO CALP. H Max m	PORTATA Kg
Doge 65	94 x 170	76 x 153	8,4	235

TRABATTELLI ALU / DOGE 80 - 005 BLIZ



CARATTERISTICHE:

Altezze di lavoro superiori a 10 mt, solidità e sicurezza per ogni tipo di lavoro

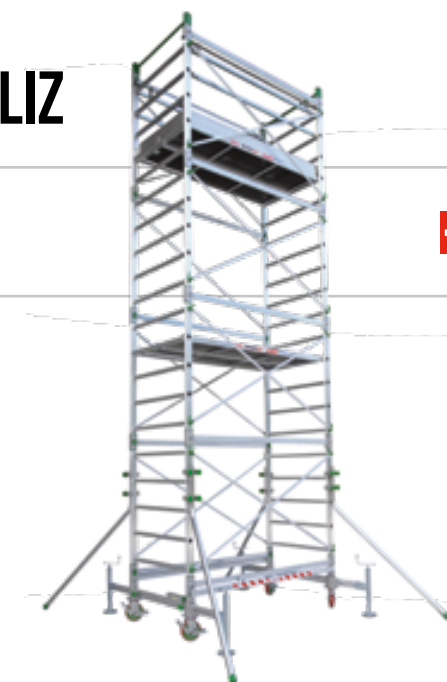

MODELLO	BASE Cm	PIANO LAVORO Cm	PIANO CALP. H Max m	PORTATA Kg
Doge 80	122 x 218	100 x 201	11,54	400
005 Bliz	200 x 200	100 x 201	12,02	300

PARAPETTO

MOD. TETTI INCLINATI



CARATTERISTICHE:

Sistemi di protezione Classe B. Certificato ISPESL. Normativa UNI-EN 13374/04

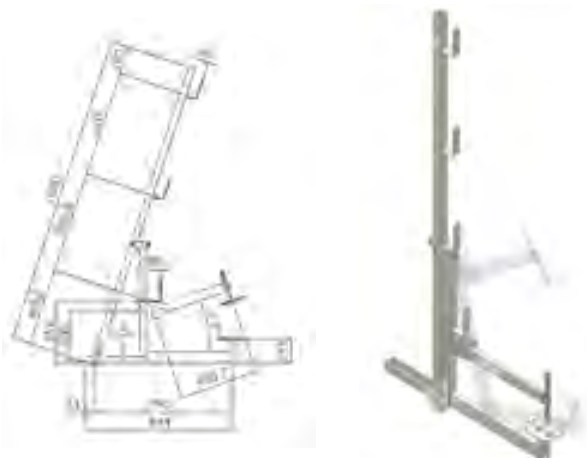

MODELLO	STATO	PESO Kg	APERTURA MORSETTO mm
113 B	Zincato	12,2	80/470

PARAPETTO

MOD. A MENSOLA



CARATTERISTICHE:

Sistemi di protezione Classe B. Certificato ISPESL. Normativa UNI-EN 13374/04

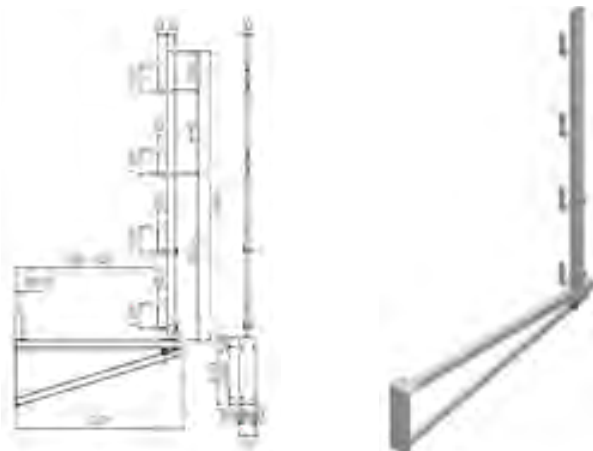

Fissaggi (tasselli) escluso

MODELLO	STATO	PESO Kg	APERTURA MORSETTO mm
115 MP	Zincato	10,8	1204

PARAPETTO

MOD. PER CORDOLO



CARATTERISTICHE:

Sistemi di protezione Classe B. Certificato ISPESL. Normativa UNI-EN 13374/04



MODELLO	STATO	PESO Kg	APERTURA MORSETTO mm
114 F	Zincato	5,8	80/500

PARAPETTO

MOD. A VITE UNIVERSALE



CARATTERISTICHE:

Sistemi di protezione Classe B. Certificato ISPESL. Normativa UNI-EN 13374/04

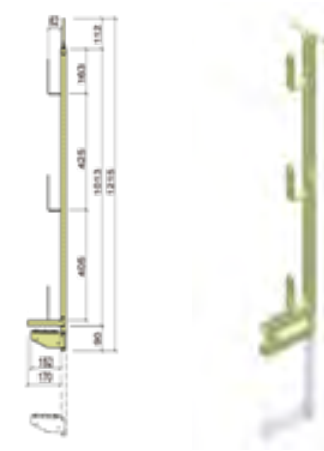

MODELLO	STATO	PESO Kg	APERTURA MORSETTO mm
103	Zincato	5	800

PARAPETTO

MOD. SOTTOVELETTA



CARATTERISTICHE:

Sistemi di protezione Classe B. Certificato ISPESL. Normativa UNI-EN 13374/04

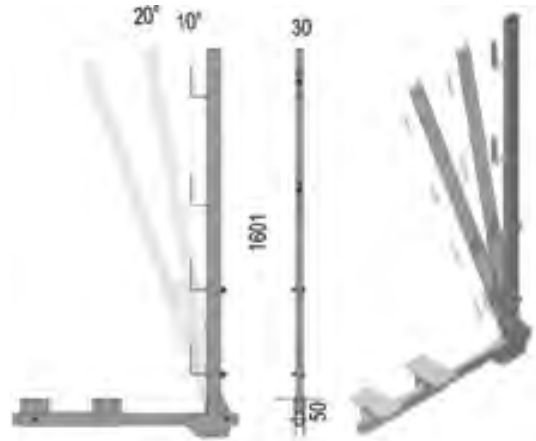

Fissaggi (tasselli) escluso

MODELLO	STATO	PESO Kg	APERTURA MORSETTO mm
115 HD	Zincato	15	510 - 1070

PARAPETTO MOD. FRONTALE E LATERALE PER TRAVE IN LEGNO



CARATTERISTICHE:

Sistemi di protezione Classe B. Certificato ISPESL. Normativa UNI-EN 13374/04

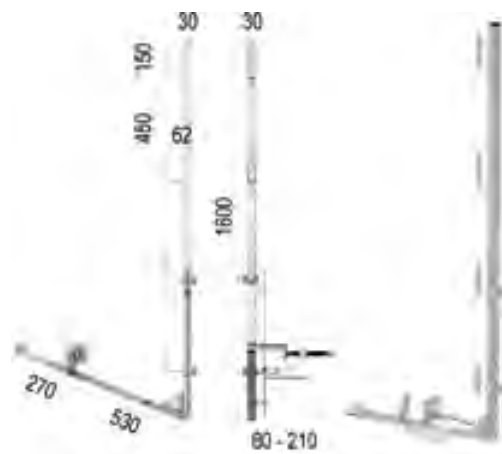

MODELLO	STATO	PESO Kg	APERTURA MORSETTO mm
112 FR	Zincato	9	80 - 210
112 LS	Zincato	9	80 - 190

PUNTELLO ALTA PORTATA



CARATTERISTICHE:

Puntello ad alta portata



SCHEDA TECNICA - Modello	Dimensione mt	Portata Min kN	Portata Max kN
Puntello alta portata Classe C45 Kg 24,55	2,60 x 4,50	13,33	35
Puntello alta portata Clas. E35 (per velox) Kg 28	2,00 x 3,50	31,7	40
Puntello alta portata Classe B35 Kg 17,6	2,00 x 3,60	11,7	30,9
Prolunga puntello Clas. E35 (per velox) Kg 6	1,00	25,5	40
Forca puntello	-	-	-
Arresto di testa	-	-	-
Tripiede per puntello	-	-	-

NB: 1 kN = 102 Kg



GRUPPI ELETTOGENI



MACCHINE EDILI



ATTREZZATURE EDILI



BOX E RECINZIONI

GRUPPI ELETTROGENI

MOSA

CARATTERISTICHE:

Gruppi portatili, alternatore monofase e trifase



Consumi medi riferiti con utilizzo del 75% della potenza totale del gruppo

MODELLO	PESO Kg	MOTORE	POTENZA Kw effettivi	SERBATOIO lt	CONSUMI lt/h
GE 4500 HBS	53	Honda 4t	3,5	5,3	3,1
GE 7000 BS/GS	82	Honda 4t	6	6,1	2,5
GE 7500 BS/GS	87	Honda 4t	6,5 / 7,5	6,1	2,5

GRUPPI ELETTROGENI

MOSA

CARATTERISTICHE:

Alternatore sincrono trifase, raffreddati ad acqua supersilenziati, quadro manuale digitale



MODELLO	PESO Kg	MOTORE	POTENZA Kw effettivi	SERBATOIO lt	CONSUMI lt/h
GE 20 YSX	700	Diesel	16 / 20	60	4
GE 35 YSX	960	Diesel	28	100	7
GE 40 VSX	930	Diesel	32	68	8

GRUPPI ELETTROGENI

MOSA

CARATTERISTICHE:

Supersilenziati, alternatore sincrono trifase, quadro manuale digitale



MODELLO	PESO Kg	MOTORE	POTENZA kVA	SERBATOIO lt	CONSUMI lt/h
GE 45YSX	1020	Diesel	46	100	704
GE 85 JMSX	1715	Diesel	88	230	14

GRUPPI ELETTROGENI

MOSA

CARATTERISTICHE:

Supersilenziati, alternatore sincrono trifase, quadro manuale digitale



MODELLO	PESO Kg	MOTORE	POTENZA kVA	SERBATOIO lt	CONSUMI lt/h
GE 140 FSX	1700	Diesel	140	230	20

GRUPPI ELETTROGENI

MOSA

CARATTERISTICHE:

Supersilenziati, alternatore sincrono trifase, quadro manuale digitale



MODELLO	PESO Kg	MOTORE	POTENZA kVA	SERBATOIO lt	CONSUMI lt/h
GE 165 PMSX	2230	Diesel	165	230	35

PALLONE LUMINOSO



CARATTERISTICHE:

Luce priva di riflessi abbaglianti, facili da montare e trasportare, adatte per cantieri e nel traffico stradale



MODELLO	H PUNTO LUCE mt	ALIMENTAZIONE	PESO Kg	DIM. TRASPORTO mm	FLUSSO LUMINOSO
LB 80 M	5	220 V	8,6 + 17	1350 x 230 x 452	80.000 Lumen

TORRE FARO



CARATTERISTICHE:

Carrello di traino manuale, versatilità di utilizzo in qualsiasi ambiente di lavoro



Macchina necessaria al funzionamento:

Gruppo GE 7000



MODELLO	H PUNTO LUCE	PESO Kg	DIM. TRASPORTO mm	FLUSSO LUMINOSO
TFMM5.5	5.5	110	1470 x 1060 x 2120	4 x 500 W

SPRUZZATORI DI COLORE AIRLESS



CARATTERISTICHE:

Spruzzatori Airless di vernici, isolanti e stucchi Strumenti per grossi lavori di verniciatura



MODELLO	PESO Kg	PORTATA MAX L/min	ALIMENTAZIONE	TUBO m
ST MAX 395	19	1,9	Monofase 220V	15 per pittura normale
MARK VII	63	6	Monofase 220V	35 per pittura normale e speciale

ALZALASTRE PER CARTONGESSO



CARATTERISTICHE:

Ideale per movimentazione lastre in cartongesso Treppiede facile da montare e smontare



MODELLO	PESO Kg	PORTATA Kg	ALTEZZA MAX m
ECO LIFT	30	68	3,35

TAGLIACAPPOTTI



Una nuova edilizia

CARATTERISTICHE:

Goniometro di precisione per regolazione inclinazione Taglierina professionale per pannelli EPS e XPS



MODELLO	LUNGH. MAX TAGLIO mm	H MAX TAGLIO mm	PESO Kg
CUT 1200	1370	330	15,6

INTONACATRICI E TRASPORTATRICI MOD. MINI AVANT

TURBOSOL

CARATTERISTICHE:

Intonacatrici e trasportatrici di malte comuni e speciali - MONOFASE



SCHEMA TECNICA	
Motore elettrico	2,2 kW - 200V
Portata	24 ÷ 30 Lt/m
Pressione massima	15 Bar
Altezza servita	12 ÷ 15 m
Distanza servita	40 ÷ 50 m
Granulometria	0 ÷ 6 m
Capacità tramoggia	140 Lt
Altezza di carico	64 cm
Dimensioni (LxPxH)	163 x 85 x 78 cm
Peso	230 Kg

MISCELATRICI E TRASPORTATRICI MOD. TM 330 EB/P

TURBOSOL

CARATTERISTICHE:

Miscelatrici e trasportatrici elettriche di massetti per sottofondi



SCHEMA TECNICA	
Motore elettrico	5,5 kW - 380V
Aria richiesta	2400 Lt/m a 6 Bar
Capacità serbatoio	330 Lt
Resa per ciclo	250 ÷ 270 Lt
Ciclo per ora	17 ÷ 19
Altezza massima pompaggio	70 m
Distanza massima pompaggio	120 m
Benna di carico	Sì
Pala raschiante	Sì
Dimensioni (LxPxH)	266 x 134 x 141 cm
Peso	975 Kg

Macchinari necessari al funzionamento:



Gruppo GE 33 VSX



Compressore MDVN 45AP

INTONACATRICI PER PREMISCELATI

MOD. GIOTTO

TURBOSOL

CARATTERISTICHE:

Intonacatrici per premiscelati asciutti



SCHEMA TECNICA	
Motore elettrico	2,2 kW - 200V
Portata	24 ÷ 30 Lt/m
Pressione massima	15 Bar
Altezza servita	12 ÷ 15 m
Distanza servita	40 ÷ 50 m
Granulometria	0 ÷ 6 m
Capacità tramoggia	140 Lt
Altezza di carico	64 cm
Dimensioni (LxPxH)	163 x 85 x 78 cm
Peso	230 Kg
Dimensioni (LxPxH)	163 x 85 x 78 cm
Peso	230 Kg



INTONACATRICI PER PREMISCELATI

MOD. DM-16/C

GIURIATO
Una nuova edilizia

CARATTERISTICHE:

Intonacatrici per premiscelati, colla, massetti, intonaci di base - monofase



SCHEMA TECNICA	
Motore elettrico	2,2 kW - 200V
Portata	24 ÷ 30 Lt/m
Pressione massima	15 Bar
Altezza servita	12 ÷ 15 m
Distanza servita	40 ÷ 50 m
Granulometria	0 ÷ 6 m
Dimensioni (LxPxH)	163 x 85 x 78 cm
Peso	230 Kg



SEGHE TAGLIAGIUNTI

clipper

CARATTERISTICHE:

Taglio asfalto, cemento armato, pavimenti e creazione giunti di dilatazione



MODELLO	PESO Kg	DISCO Ø mm	PROF. DI TAGLIO MAX mm	MOTORE	AVANZAMENTO
C 451	78	400	165	Honda 4t	Manuale
CS 1	135	450 / 500	185	Honda 4t	Manuale

SEGHE TAGLIAGIUNTI

TYROLIT

CARATTERISTICHE:

Avanzamento elettrico per tagli profondi



MODELLO	PESO Kg	DISCO Ø mm	PROF. DI TAGLIO MAX mm	MOTORE	AVANZAMENTO
HFS 620/c/disco	310	600	220	Benzina	Manuale
HFS 722/c/disco	365	700	270	Diesel	Automatico

MOTOTRONCATRICI A SCOPPIO

Makita

CARATTERISTICHE:

Con sistema anti vibrazione - a 2 tempi



MODELLO	PESO Kg	DISCO Ø mm	PROF. DI TAGLIO MAX mm	MOTORE
DPC 7301	10	350	125	2t
EK 8100 WS	10,6	400	145	2t

TAGLIERINE A BANCO AD ACQUA

clipper

CARATTERISTICHE:

Ottima per taglio in cantiere di Poroton Laterizi - Cemento



MODELLO	PESO Kg	DISCO Ø mm	PROF. DI TAGLIO MAX mm	ALIMENTAZIONE
TM 80	95	400	145	Monofase

SEGA A NASTRO TAGLIO SECCO

clipper

CARATTERISTICHE:

Taglio laterizi porizzati - Poroton - Mattoni pieni Calcestruzzo cellulare - Gasbeton / Yton



MODELLO	H. TAGLIO mm	L. TAGLIO mm	PESO Kg	PIANO SCORR. mm
SPH 505R	500	660	220	710 x 1060

CAROTATRICI FISSE CON SUPPORTO

TYROLIT

CARATTERISTICHE:

Carotaggio ad umido fino a Ø 300 mm



MODELLO	TIPO	PESO Kg	UTILIZZO	Ø MAX	ALIMENTAZIONE
DRU250P	Fissa	20,8	Umido	250	Monofase
DME32	Fissa	23	Umido	250	Monofase
HCCB-5V	Fissa	29,9	Umido	300	Monofase

CAROTATRICI PORTATILI

TYROLIT

CARATTERISTICHE:

Carotaggio a secco / umido



MODELLO	TIPO	PESO Kg	UTILIZZO	Ø MAX	ALIMENTAZIONE
DM22PU	Portatile	4,6	Secco/Umido	160	Monofase
DME32	Portatile	4,6	Secco/Umido	160	Monofase

FORETTI A SECCO LUNGHEZZA 150 / 250 MM

TYROLIT

CARATTERISTICHE:

Foretti a secco per muro in cotto / cemento



MODELLO	DIAMETRO mm
Foretti a secco	Ø 51 - 61 - 71 - 81 - 91 - 101 - 107 - 127
Foretti a secco	Ø 132 - 142 - 152 - 162

FORETTI A UMIDO LUNGHEZZA 450 MM

TYROLIT

CARATTERISTICHE:

Foretti a umido per cemento armato e generici



MODELLO	DIAMETRO mm
Foretti a umido attacco 1" / 4	Ø 62 - 72 - 82 - 92 - 102 - 112 - 122 - 127 - 132
Foretti a umido attacco 1" / 4	Ø 142 - 152 - 162 - 182 - 202 - 225 - 250 - 302

ASPIRATORI POLVERI / LIQUIDI

TYROLIT

CARATTERISTICHE:

Aspiratore per carotaggio a secco, aspirapolvere generico e aspira liquidi



MODELLO	CAPACITÀ lt	POTENZA WATT	FLUSSO ARIA lt/min	RUMOROSITÀ dB	PESO Kg
447L	27	2400	55	57	16

MARTELLI DEMOLITORI

Makita



MODELLO	PESO Kg	POTENZA WATT	POTENZA DEL COLPO J	FREQUENZA COLPI
HM 0871 C	6,4	1100	8,1 J	1100 - 2650 / min
HM 1111 C	8	1300	11,2 J	1100 - 2650 / min
HM 1214 C	12,3	1510	19,9 J	950 - 1900 / min
HM 1317 C	17	1510	25 J	730 - 1450 / min
HM 1812 C	31,3	2000	72,8 J	870 / min

FLESSIBILE CON DISCO

Makita



MODELLO	PESO Kg	POTENZA WATT	VELOCITÀ giri / min	Ø DISCO mm	TENSIONE
GA9030 R	6,3	2400	6600	230	220 V

AVVITATORE AD IMPULSI

Makita



MODELLO	PESO Kg	POTENZA WATT	BULLONI	VEL. VUOTO g / min	COPIA DI SERRAGGIO
TW0200	2,2	380	M10-M16	0 - 2200	200 Nm

MARTELLI DEMOLITORI ROTATIVI

Makita



MODELLO	PESO Kg	POTENZA WATT	POTENZA DEL COLPO J	Ø FORO CALCESTRUZZO mm
HR 4013 C	6,8	1100	8,0 J	16 - 30
HR 4511 C	8,8	1350	9,4 J	20 - 35
HR 5212 C	12,1	1500	18,9 J	25 - 40

TASSELLATORI TRAPANI AVVITATORI A BATTERIA

Makita



MODELLO	PESO Kg	BATTERIE	POTENZA DEL COLPO J	Ø FORO CALC. mm	Ø FORO LEGNO mm
DHP 481 RTJ	2,4	18 V / 5,0 Ah	-	6 - 14	12
DHR 263 PT 2J	4,6	2 x 18 V / 5,0 Ah	2,5 J	6 - 16	32

TASSELLATORE ELETTRICO

Makita



MODELLO	PESO Kg	POTENZA WATT	POTENZA DEL COLPO J	Ø FORO CALC. mm	Ø FORO LEGNO mm
HR 2811 FT	3,6	800	2,9 J	8 - 18	32

SEGHE CIRCOLARI



MODELLO	PESO Kg	POTENZA WATT	PROFONDITÀ DI TAGLIO mm	VEL. VUOTO g/min	Ø LAMA mm
5903 RK	7,2	2000	85	4500	235

SEGHETTO DIRITTO A BATTERIA



MODELLO	PESO Kg	POTENZA WATT	PROFONDITÀ DI TAGLIO mm	VEL. VUOTO c/min	REGOLAZIONE VELOCITÀ
JR 3070 CT	4,4	1510	255	0 - 2800	6

MISCELATORI



MODELLO	PESO Kg	POTENZA WATT	VEL. VUOTO g/min	VEL. SOTTO SFORZO g/min	MISCELAZIONE max
UT 1400	5,2	1300	0 - 900	0 - 580	50 Kg

LEVIGATRICE A NASTRO



MODELLO	PESO Kg	POTENZA WATT	DIMENSIONI NASTRO mm	VEL. VUOTO mt/min
9902	4,3	1010	75 - 533	210 - 440

SCANALATORI A DISCHI E A RULLI



MODELLO	PESO Kg	POTENZA WATT	PROFONDITÀ TRACCIA mm	Ø MAX mm
RDS 190	6,3	1800	0 - 60	190
BMF 500	3	1020	23 - 38	Rulli

LEVIGATRICI PER INTONACI E CEMENTO



MODELLO	PESO Kg	POTENZA WATT	ALIMENTAZIONE V	Ø ASPORTAZ. mm
RL 80	3,7	750	220	80
RL 120	5,4	1200	220	125

FRATTAZZATRICE

GIURIATO
Una nuova edilizia

CARATTERISTICHE:
Per malta fina e grossa

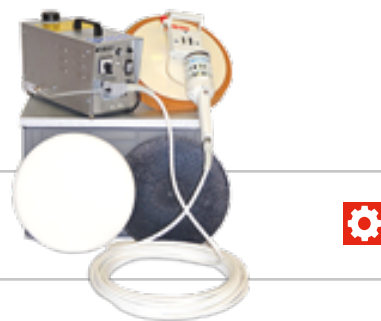

MODELLO	TENSIONE	POTENZA	VELOCITÀ ROTAZIONE	Ø DISCO	LUNGH. GUAINA FLESSIBILE	PESO UNITÀ FLESSIBILE	DIM. COTENITORE
DM1	220 V	0,5 kW	80 - 150 giri/min	400 mm	17 m	4 Kg	600 x 400 x 420

LEVIGATRICI A GIRAFFA CON ASPIRATORE

SPIT

CARATTERISTICHE:
Rimozione intonaci e levigatura cartongesso aspiratore con pulizia filtri I-Pulse



MODELLO	PESO Kg	ALIMENTAZIONE	Ø ASPORTAZ. mm	POTENZA W
DWS 225	4,6	220 V	1520	550
Aspiratore Star mix 1635	15,7	220 V	-	1600

ASPIRAFUMI / VENTILATORI

GIURIATO
Una nuova edilizia

CARATTERISTICHE:
Aspiratore per polveri e fumi



MODELLO	PESO Kg	ALIMENTAZIONE	LUNGHEZZA TUBO m
Vaf 3000	18	220 V	7,5

LEVIGATRICI PER PAVIMENTI

TYROLIT

CARATTERISTICHE:
Per levigatura, rimozione e livellamento pavimento per installazione nuove piastrelle

Disponibilità di vari utensili diamantati per la rimozione di diversi tipi di rivestimenti:

- Rimozione pesante
- Levigatura grezza
- Levigatura fine



MODELLO	PESO Kg	ALIMENTAZIONE V	POTENZA kW	LARGHEZZA LAVORO mm
FGE 270	53	Monofase 380	1,5	270

SCARIFICATRICI

T
Trimmer

CARATTERISTICHE:
Asportazione materiale vario, vecchia segnaletica orizzontale, per rigare pavimenti

MODELLO	PESO Kg	ALIMENTAZIONE	POTENZA kW	LARGHEZZA LAVORO mm
TR 200	58	Monofase	2,2	200



LISCIATRICI

RAIMONDI

CARATTERISTICHE:
Lisciatura massetti, levigare e carteggiare superfici, per lavaggio pavimenti e trattamento cotto toscano

MODELLO	PESO Kg	ALIMENTAZIONE	FUNZIONE
Maxititina	23,2	Disco	Lisciatrice
Supertitina	23	Disco	Lisciatrice



TAGLIAPIASTRELLE / TAGLIABETONELLE

sigma

CARATTERISTICHE:
Incisione veloce a trazione



MODELLO	PESO Kg	SPESSORE mm	LUNGH. TAGLIO mm
Tagliapiastrelle	10	20	620
Tagliabetonelle Montolit	49	145	310

TAGLIASASSI / CESCOIE ELETTRICHE

EDILGRAPPA

CARATTERISTICHE:
Corpi a cesoia con testa intercambiabile



MODELLO	PESO Kg	TESTA	ALIMENTAZIONE	Ø TAGLIO mm
TS 500	150	Spaccasassi	Monofase	215
T 20	4,7	Fissa	Monofase	20
MU 16	4,9	Forbice	Monofase	16

PULITAVOLE

EDIL-FA

CARATTERISTICHE:
Per pulizia pannelli e tavole in legno da armatura



MODELLO	PESO Kg	ALIMENTAZIONE	POTENZA kW	SPESSORE LAVORO cm
3P OTTANTA	260	Monofase	0,95	1-5

AGHI VIBRANTI ELETTRICI

WACKER NEUSON

CARATTERISTICHE:
Massima vibrazione ad alta frequenza, motore integrato



* Specifico per utilizzo con casseforme INTERFAMA

MODELLO	PESO Kg	Ø AGO mm	VIBRAZIONE g/min	ALIMENTAZIONE
IRFUN 45	15,4	45	12000	Monofase
ARFU 36*	14,2	Mors. Interfama	6000	Monofase
Ago + convertitore	23,2	50	6000	Monofase

BETONIERE

POLIERI

CARATTERISTICHE:
Mescolazione omogenea in monofase



MODELLO	PESO Kg	ALIMENTAZIONE	POTENZA Hp	CAPACITÀ Lt
CE 250	165	Monofase	1,5	250
CE 300	204	Monofase	2	300

SCARICA DETRITI

GIURIATO
Una nuova edilizia

CARATTERISTICHE:
Con supporto per murette, davanzali e finestre



MODELLO	PESO Kg	Ø FORO mm	ALTEZZA mm
Tubo con catene	9	400	1100
Tramoggia con supporto	13	360	900

IDROPULTRICI ACQUA FREDDA



CARATTERISTICHE:
Ugello turbo per max pressione



MODELLO	PESO Kg	ALIMENTAZIONE	PRESSIONE Bar	ACQUA
Idropulitrice	24	Monofase	150	Fredda

IDROPULTRICE ACQUA CALDA



CARATTERISTICHE:
Ad acqua calda per una pulizia ottimale



MODELLO	PESO Kg	ALIMENTAZIONE	SERB. COMBUST. Lt	PRESSIONE Bar	ACQUA
Idropulitrice	84	Monofase	16	120	Calda

IDROPULTRICI E IDROSABBIATRICI A SCOPPIO



CARATTERISTICHE:
Pressione a 250 bar
Pompa acqua autoadescante



Accessorio per sabbiatura

MODELLO	PESO Kg	PRESSIONE Bar	L/H	PORTATA SABBIANTE Kg/h
FDX PRO 16/250	82	250	960	200
FDX PRO 13/180	70	180	900	200

POMPE ACQUA SCOPPIO / ELETTRICHE



CARATTERISTICHE:
Con tubo manichetta. Anche per acque nere.
Elevata portata a grande prevalenza



MODELLO	PESO Kg	ALIMENTAZIONE	PREVALENZA m	PORTATA ACQUA
Drainex 100	10	Monofase	10	350 Lt/min
PT 2 A	61	Honda 2t	30	47 m³/h

ELEVATORE



CARATTERISTICHE:
Portata fino a 200 kg - Disponibile anche cavalletto



MODELLO	PESO Kg	ALIMENTAZIONE	LUNGH. FUNE m	PORTATA Kg
SUM 210 ZP	35	Monofase	25	200

SEMAFORI MOBILI A LED



CARATTERISTICHE:
Ingombro ridotto, elevatissima efficienza luminosa a led



MODELLO	PESO Kg	ALIMENTAZIONE	CENTRALINE
Semafori mobili a led	80	12 V/220 V	Digitali

MOTOCOMPRESSORI MOD. MDVN 45 AP / VRK 185 D

ROTAR

CARATTERISTICHE:

Utilizzati con sabbiatrici, strumenti pneumatici, martelli, ceselli, svitatori... compatti ed ergonomici



Compressore MDVN 45 AP



Compressore VRK 185 D

MODELLO	PESO Kg	ARIA RESA Kg	LARGHEZZA mm	MOTORE
VRK 185 D	350	1800	1100	Diesel
MDVN 45 AP	820	4500	1340	Diesel

SABBIATRICI AD ARIA

CB

CARATTERISTICHE:

Sabbiatrici con getto comandato, per qualsiasi tipo di superficie



Macchinari necessari al funzionamento:

- Compressore MDVN 45 AP
- Compressore VRK 185 D



MODELLO	PESO Kg	PRESSIONE Bar	CAPACITÀ Lt
CB 24	32	7	24
CB 60	70	7	60

MARTELLI PNEUMATICI AD ARIA

Atlas Copco

CARATTERISTICHE:

Possibilità di lavorare a lungo ed in maniera efficiente



MODELLO	PESO Kg	CONSUMO Lt	COLPI Min
SK 50	5,0	430	2650
DK 90 LS	10,9	1100	2000
DK 170 LS	16,5	1300	1980
DK 280 LS	30,5	1800	1400

LIVELLATRICI ELICA / STADIE VIBRANTI

MAKER

CARATTERISTICHE:

Avviamento autoavvolgente, rapida levigatura e liscitura di sottofondi in calcestruzzo, facilmente manovrabii



MODELLO	PESO Kg	MOTORE t	Z mm STADIA mm
LS 90	75	Honda 4t	900
Libellula	13	2t	1500

GENERATORI ARIA CALDA

GIURIATO
Una nuova edilizia

CARATTERISTICHE:
A gasolio, gas, elettrico.



MODELLO	PESO Kg	Kcal/h	PORTATA ARIA m³/h	ALIMENTAZIONE
Kid 40 / 60	13 / 20	37400 / 50200	850 / 1800	220 V
Mirage 37 H	70	31300	2000	220 V / gasolio
Mirage 55 / 65 H	80	50200	3000	220 V / gasolio
Mirage 85 H	121	72200	4500	220 V / gasolio

ASPIRAPOLVERI / LIQUIDI

FASA
ITALY

CARATTERISTICHE:
Sistema aspirante con raffreddamento by pass



MODELLO	CAPACITÀ SERB. Lt	ALIMENTAZIONE	Motore W
DOMINIO 78 INOX	78	Monofase	2400

DEUMIDIFICATORI

GIURIATO
Una nuova edilizia

CARATTERISTICHE:
Sistema di raccolta d'acqua ad arresto automatico



MODELLO	PESO Kg	ARIA TRATTATA m³/h	POTENZA W	SERBATOIO Lt
XRC 55 / 90	57 / 63	600 / 800	837 / 1236	10 / 10

PANNELLI RECINZIONE

GIURIATO
Una nuova edilizia

CARATTERISTICHE:
Leggeri e resistenti



MODELLO	PESO Kg	LUNGHEZZA m	ALTEZZA m
Pannello recinzione*	18	3,5	2
Pannello recinzione*	16	3,5	1,2

* Piedino PVC compreso (28 Kg)

TRANSENNE IN PVC / FERRO

GIURIATO
Una nuova edilizia

CARATTERISTICHE:
Delimitatore di aree



MODELLO	PESO Kg	LUNGHEZZA m	ALTEZZA m
Transenne in PVC	10	2,15	120
Transenne in Ferro	18,5	2,15	120

MONOBLOCCHI COIBENTATI USO UFFICIO



CARATTERISTICHE:

Ottima coibentazione ed isolamento acustico
Installazione rapida sul posto



MODELLO	PESO Kg	LUNGHEZZA m	LARGHEZZA m	ALTEZZA mv
Monoblocco 3m	700 / 630	3,09	2,34 / 2,00	2,40
Monoblocco 4m	850	4,09	2,34	2,40
Monoblocco 5m	1000	5,09	2,34	2,40

CONTAINER USO MAGAZZINO

CTX CONTAINERS

CARATTERISTICHE:

Movimentazione con gru o muletto,
ideale per la sicurezza dei tuoi attrezzi



MODELLO	PESO Kg	LUNGHEZZA m	LARGHEZZA m	ALTEZZA m
Container LC 8	715	2,44	2,20	2,26
Container LC 10	955	3,00	2,44	2,59
Container LC 15	1030	4,55	2,20	2,26

BAGNI CHIMICI



CARATTERISTICHE:

Pronto all'uso, non necessita di allacciamenti idro fognari



Canone di noleggio personalizzato

Condizioni di noleggio: fatturazione diretta da SEBACH

Noleggiare un bagno chimico SEBACH è semplice: viene consegnato pronto all'uso e non necessita di allacciamenti idrico-fognari-elettrici.

Cosa comprende il canone di noleggio:

- consegna direttamente in cantiere
- 4 cicli di pulizia (1 a settimana)
- ritiro a fine del noleggio
- ASSICURAZIONE: furto, incendio e atti vandalici



ELIET

SUPER PROF



MACCHINE AGRICOLE



ATTREZZATURE AGRICOLE

BIOTRITURATORE A SCOPPIO

ELIET

CARATTERISTICHE:

Riduzione dei tempi e massima resa lavoro



MODELLO	PESO Kg	MOTORE	Diam. Max macinabile mm	DIMENSIONI BOCCA mm	AVANZAMENTO
Major 45 GX270	135	Benzina HP 9	55	245 x 250	Manuale
Superprof Max	441	Benzina HP 23	140	500 x 700	Semovente / Idraulico

TRINCIASARMENTI

GIURIATO
Una nuova edilizia

CARATTERISTICHE:

Idrostatico, controllo di direzione marcia assistita



MODELLO	PESO Kg	MOTORE	LARGHEZZA LAVORO cm	AVVIAMENTO	AVANZAMENTO
655 HD8	92	Benzina 8 Hp	50	manuale	idrostatico assistito

FRESACEPPI

RAYCO

CARATTERISTICHE:

Possibilità di fresare il ceppo fino a 50 cm di profondità dal suolo, robustezza, semplicità e sicurezza



MODELLO	PESO Kg	MOTORE	Larghezza ceppo macinabile	AVVIAMENTO	AVANZAMENTO
Rayco RG - 25 HD	295	Benzina 25 HP	Illimitata	Elettrico	Semovente / Idraulico

CATENARIA SEMOVENTE / MANUALE

BARRETO

CARATTERISTICHE:

Selezionabili diverse profondità di scavo



MODELLO	PESO Kg	MOTORE	PROFONDITÀ DI LAVORO cm	LARGHEZZA SCAVO cm	AVANZAMENTO
TR - 12 H	105	Benzina HP 5,5	da 10 a 35	10	Manuale
Barreto 712 - 30 H	181	Benzina HP 6,5	da 10 a 35	10	Semovente / Idraulico

ARIEGGIATORE SEMOVENTE

GIURIATO
Una nuova edilizia

CARATTERISTICHE:

Pulizia feltro e muschio senza strappare il manto erboso, semovente



MODELLO	PESO Kg	MOTORE	LARGHEZZA DI LAVORO cm	ROTORE A LAME	AVANZAMENTO
Classen TRS-20 H	97	Benzina 5,5 HP	50	28 Mobili	Idrostatico

ARIEGGIATORE MANUALE

GIURIATO
Una nuova edilizia

CARATTERISTICHE:

Pulizia feltro e muschio senza strappare il manto erboso



MODELLO	PESO Kg	MOTORE	LARGHEZZA DI LAVORO cm	ROTORE A LAME	AVANZAMENTO
Classen TR-20 H	61	Benzina 5,5 HP	50	28 Mobili	Manuale

CAROTATRICE

GIURIATO
Una nuova edilizia

CARATTERISTICHE:

Permette di far respirare il terreno così da sviluppare un migliore apparato radicale



MODELLO	PESO Kg	MOTORE	LARGHEZZA DI LAVORO cm	PROFONDITÀ DI CAROTATURA CM	PRODUTTIVITÀ mq/h
Ryan Lawnaire	103	Benzina 4 HP	67,3	7	3700

SCACCIA TALPE

GIURIATO
Una nuova edilizia

CARATTERISTICHE:

Scaccia talpe e topi campagnoli



MODELLO	PESO Kg	MOTORE	LARGHEZZA cm	LUNGHEZZA cm	ALTEZZA cm
Mauki	37	Benzina HP 6,5	59	126	64

SPANDISABBIA

GIURIATO
Una nuova edilizia

CARATTERISTICHE:

Per distribuzione di sabbia e terriccio



MODELLO	LARGHEZZA DISTIBUZIONE cm	CAPACITÀ lt	LARGHEZZA TOTALE cm	NUMERO RUOTE
Mini Topper P	60	100	89	4

IRRORATRICE

GIURIATO
Una nuova edilizia

CARATTERISTICHE:

Ideale per irrigare il terreno con acqua e prodotti vari



MODELLO	CAPACITÀ SERBATOIO lt	LARGHEZZA DI LAVORO cm	SUPERFICIE COPERTA mq
Acuspray	25	150	650

MOTOTRIVELLE A SCOPPIO



CARATTERISTICHE:

Diametro 100 / 200, facile da utilizzare



MODELLO	PESO Kg	MOTORE t	POTENZA Hp	ROTORE A LAME	PROFONDITÀ mm
C 50	19	2	2	28 Mobili	Idrostatico

TAGLIASIEPI



CARATTERISTICHE:

Ideale per regolare la siepe senza far fatica



MODELLO	PESO Kg	MOTORE	LUNGHEZZA BARRA mm	CAPACITÀ DI TAGLIO mm	VELOCITÀ A VUOTO
UH 55 70	3,7	550 W	550	18	1600 giri / min

ELETTROSEGHE



CARATTERISTICHE:

Tensionamento catena senza uso di utensili. Impugnatura Soft Grip. Potenza Assorbita



MODELLO	PESO Kg	MOTORE	LARGHEZZA DI TAGLIO MAX mm	VELOCITÀ	DIMENSIONI mm
UC 3541 A	4,7	1800 W	325	880 g/mm	455 x 246 x 201

TAGLIAERBA



CARATTERISTICHE:

Semovente, 3 velocità



MODELLO	PESO Kg	MOTORE	LARGHEZZA cm	ALTEZZA TAGLIO mm	AVANZAMENTO
PLM5113N	37,7	190 cm ³	51	25 / 70	Semovente 3 vel.

TRINCIA MULCHING



CARATTERISTICHE:

Mulching, semovente



MODELLO	PESO Kg	MOTORE	LARGHEZZA cm	ALTEZZA TAGLIO mm	AVANZAMENTO
PLM5121	31,7	190 cm ³	51	25 / 70	Semovente

DECESPUGLIATORI A SCOPPIO



CARATTERISTICHE:

Lama in ferro / plastica

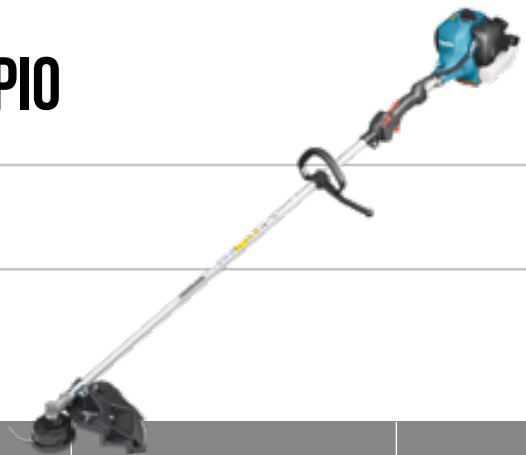

MODELLO	PESO Kg	MOTORE	POTENZA
EBH 341L	10,2	4 tempi	1,4 Hp







DAL 1965

NON SOLO NOLEGGIO

I NOSTRI SERVIZI

Dal 1965 siamo il punto di riferimento per la vendita, il noleggio e l'assistenza di macchine ed attrezzature edili delle migliori marche. La nostra forza sta nel fornire macchine e attrezzature di altissima qualità, materiali sicuri e servizi vantaggiosi proposti da un team di professionisti che vi seguiranno ad ogni passo.

VENDITA MACCHINE E ATTREZZATURE EDILI

<p>Vendita, noleggio e assistenza di gru edili</p> 	<p>Vendita, noleggio e assistenza di macchine movimento terra</p> 	<p>Vendita, noleggio e assistenza di sollevatori telescopici</p> 
<p>Vendita, noleggio e assistenza di Piastre Vibranti, Vibrocospatori, Rulli compattatori, Dumper cingolati e gommati e aghi vibranti</p> 	<p>Noleggio, progettazione, consulenza e vendita di casseforme e armatura solai</p> 	<p>Vendita, noleggio e assistenza di elettroutensili</p> 
<p>Vendita, noleggio e assistenza di tagliagiunti e seghe da edilizia</p> 	<p>Vendita, noleggio e assistenza di carotatici, corone e dischi diamantati</p> 	<p>Vendita, noleggio e assistenza di gruppi elettrogeni e torri faro</p> 
<p>Vendita, noleggio di box monoblocchi e recinzioni</p> 	<p>Vendita e consulenza sistemi di fissaggio, schiume e ancoraggi chimici</p> 	<p>Noleggio, progettazione, consulenza e vendita di ponteggi in ferro ed alluminio</p>  
<p>Vendita D.P.I. Sicurezza e antinfortunistica, scarpe e abbigliamento</p> 	<p>Vendita e assistenza di Laser e strumenti di misura</p> 	<p>Vendita e noleggio di scale e trabattelli</p> 

LINEE VITA

Vendita, progettazione, consulenza e montaggio di Linee Vita e scale a gabbia, sistemi anticaduta con relazioni di calcolo.



MATERIALI EDILI

Colori, cartongesso, cappotti e prodotti per il risanamento e la finitura murale



Porte tagliafuoco, porte da interni, controtelai per porte e finestre, lucernari e scale retrattili



Guaine e membrane impermeabilizzanti



Isolamenti termici, acustici, coperture, cisterne e moduli



ASSISTENZA E CORSI DI FORMAZIONE

La divisione **Movimento Terra** a noleggio è composta da oltre 50 unità prevalentemente di Marchio Caterpillar, tutte di recente acquisizione, accessoriate con varie tipologie di attrezzature. La divisione **Gru Edili** a noleggio è composta da oltre 100 unità di varie misure e tipologie. Il servizio di montaggio, assistenza e trasporto delle Gru Edili è garantito da personale interno altamente specializzato. I trasporti sono effettuati con mezzi propri. L'attività di manutenzione, riparazione ed assistenza, delle Macchine ed Attrezzature avviene sia all'interno delle nostre sedi di **Zanè** ed **Altavilla**, sia direttamente presso i cantieri dei nostri clienti, con il nostro personale specializzato.

- Siamo Centro Vendita e Assistenza Autorizzato **Gru Edili Vicario**
- Siamo Centro Vendita e Assistenza Autorizzato **Caterpillar - Wacker Neuson - Makita**

Giuriato in collaborazione con **Fesica Confsal**, organizza corsi di formazione specifici per lavoratori sulla sicurezza nel posto di lavoro, permettendo alle aziende interessate di adempiere a tale obbligo, come previsto dal **Testo Unico sulla Sicurezza D. Lgs. 81 del 9.04.2008**.

GIURIATO, UNA NUOVA EDILIZIA

Proiettati al futuro, senza dimenticare l'esperienza maturata in cinquant'anni

ABBIGLIAMENTO, SCARPE E DPI

**NON SOLO
NOLEGGIO**
I NOSTRI SERVIZI



www.giuriato.it

www.giuriatostore.com

GIURIATO
Una nuova edilizia

SEDE:

via M. Summano, 101
36010 Zanè (VI)
t. +39 0445 315700
info@giuriato.it
www.giuriato.it

FILIALE:

via Olmo, 41 S.R.11
36077 Altavilla Vic.na (VI)
t. +39 0444 522880
info.altavilla@giuriato.it
www.giuriatostore.com

