

Gru idraulica  
di qualità  
100% Italiana

**OMV 260 - 16 m**

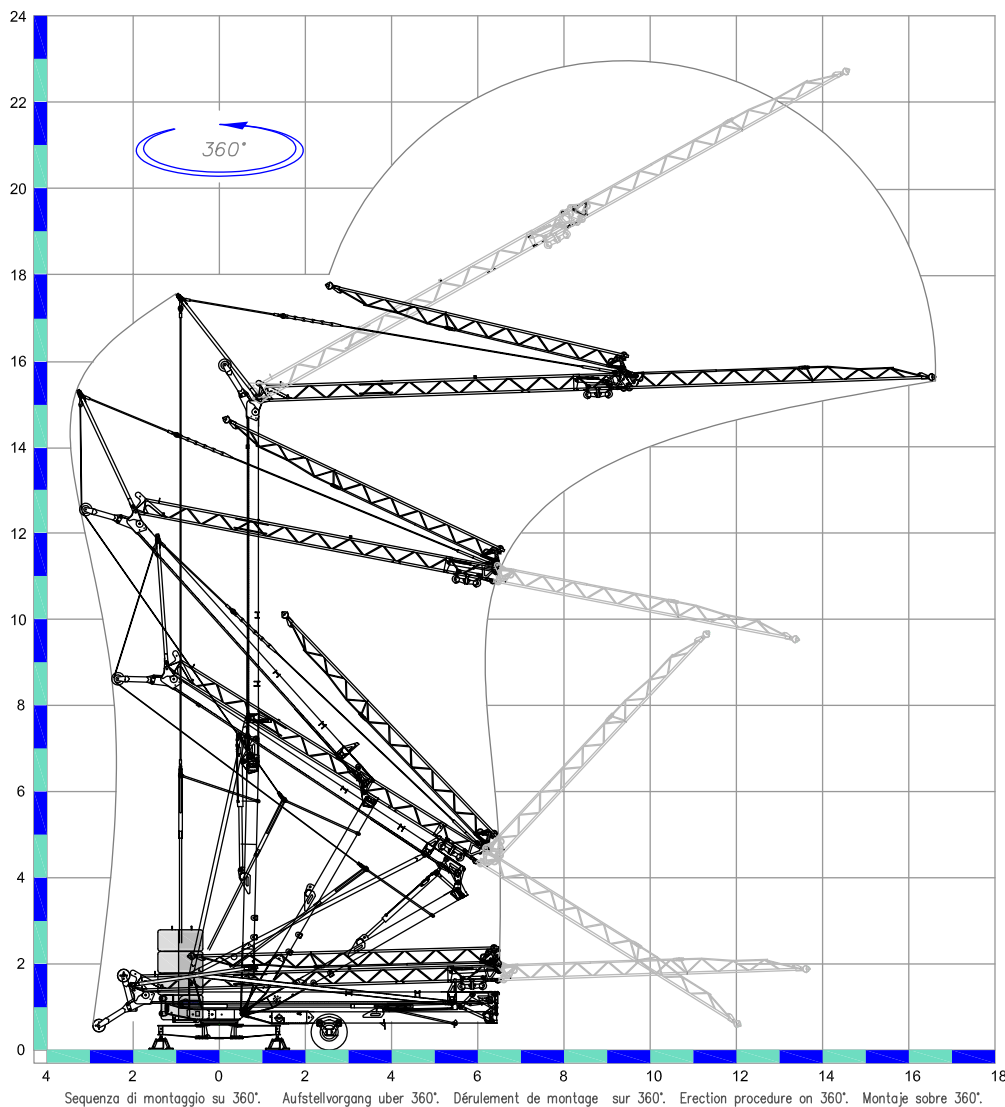

Ufficio Tecnico OMV Vicario SpA - 10106

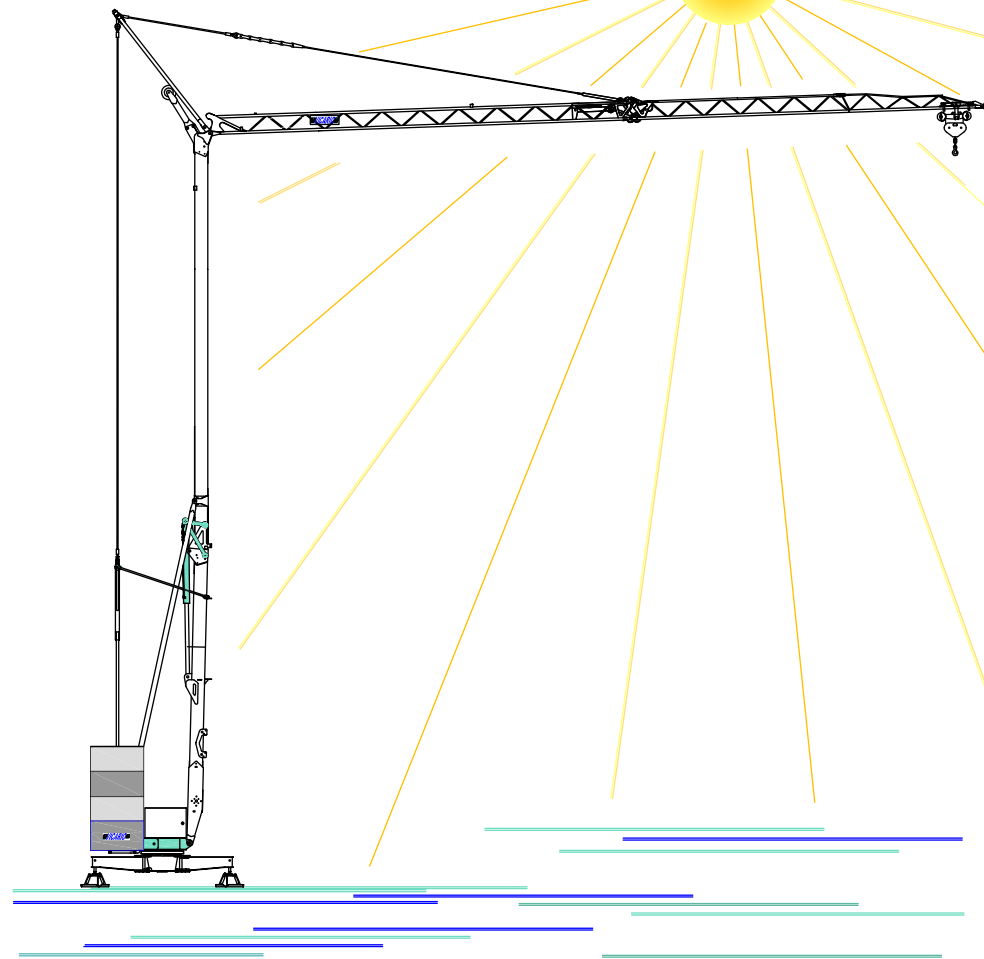

Agente di zona:

# OMV 260-16m

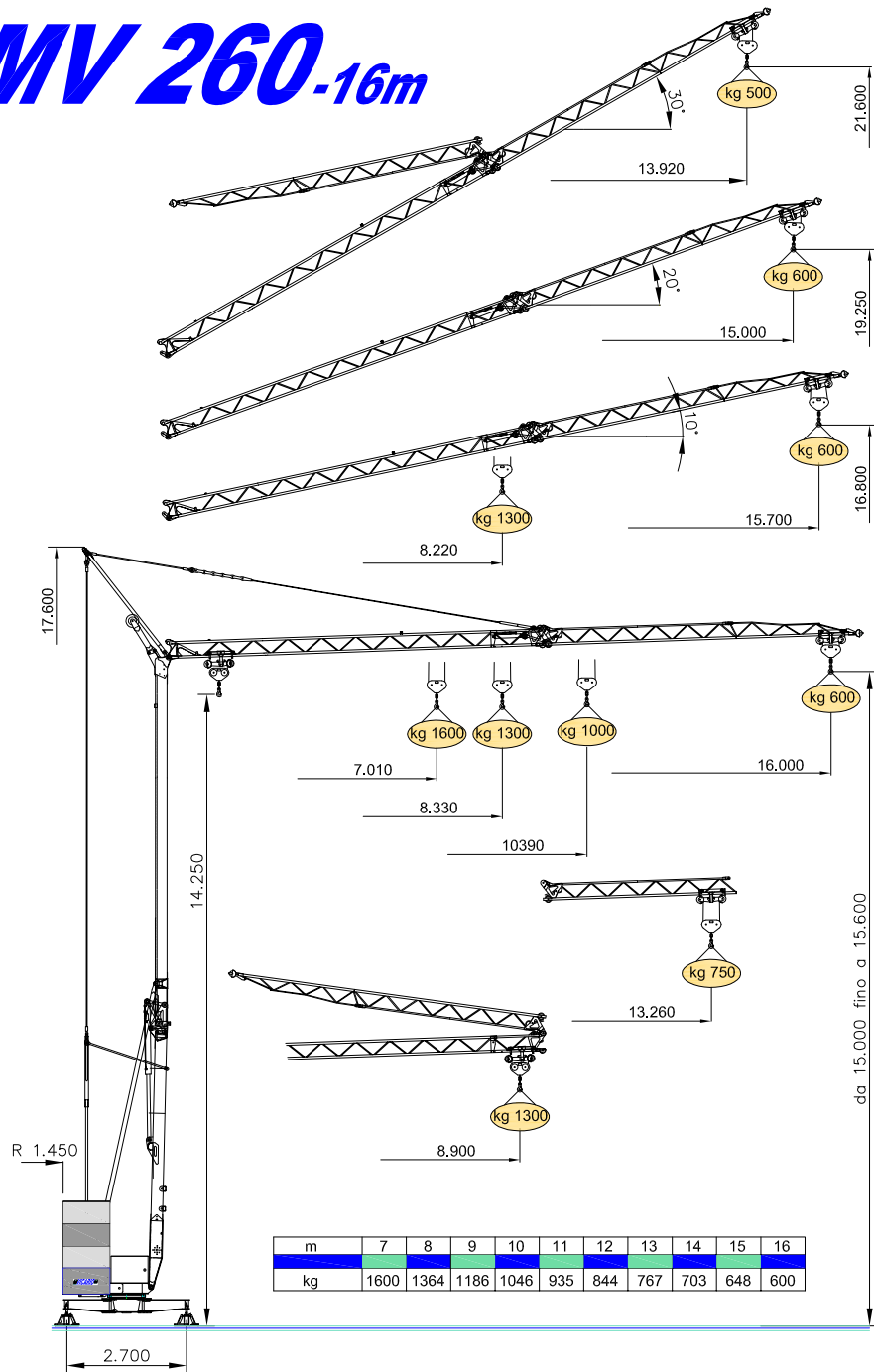

## DOTAZIONE DI SERIE

Sollevamento "overdrive" a 4 velocità con inverter, rotazione e carrello a tre velocità con inverter, zincatura della struttura e dei tiranti, contrappeso, braccio impennabile, carrello rampante con motore e finecorsa alla base della torre, funzionamento con braccio ripiegato, comando a pulsantiera via cavo, carter di protezione per ralla e meccanismi, predisposizione per autozavorramento e radiocomando, armadio elettrico in acciaio inox, documentazione a norme CEE.

## STANDARD FEATURES

4-speed lifting, 3-speed rotation and trolley with inverter control, galvanised structure, counterweight, pull-up jib, translation trolley with motor and limit switch at base of gantry, operation with folded jib, cable-operated pushbutton remote control, guard for slewing ring and mechanisms, designed to allow installation of self-ballasting device and radio control, stainless steel electrical cabinet, documentation in accordance with EU standards.

## EQUIPEMENT DE SERIE

Levage à quatre vitesses, chariot et rotation à trois vitesses à contrôle électronique, galvanisation de la structure et des tirants, contrepoids, flèche relevable, moteur de chariot et fin de course à la base de la tour, fonctionnement bras replié, commande par câble, carter de protection pour la couronne et les mécanismes, predisposition pour autoestage et commande radio, armoire électrique en acier inox, documentation conforme aux normes CEE.

## SERIENAUSSTATTUNG

Heben mit vier Geschwindigkeiten, Laufkatze und Rotation mit drei Geschwindigkeiten, Strukturverzinkung, Gegengewicht, hochklappbarer Arm, aufsteigender Wagen mit Motor und Anschlag an der Basis des Turms, Funktionieren mit eingeklapptem Arm, Steuerung mit Druckknopftaste via Kabel, Schutzvorrichtungen für Drehverbindungen und Mechanismen, Vorbereitung für Selbstballasteinahme und Funksteuerung, elektrischer Schrank aus rostfreiem Stahl, Dokumentation gemäß EC Vorschriften.

## DOTACION DE SERIE

Levantamiento a cuatro velocidades, carro y rotación a tres velocidades con control electrónico, galvanización de la estructura, contrapeso, brazo empinable, carro rampante con motor y fin de carrera en la base de la torre, funcionamiento con brazo repliegado, funcionamiento por pulsadores via cable, carter de protección para corona de giro y mecanismos, predisposición para autocontrapeso y radioccontrol, armario eléctrico de acero inox, documentación según normas CEE.

	230V (±10%) 50 Hz	3kVA			
	m/l'	5.5	11	22	28
	kg	1600	1600	600	400   600
	kW	4 (Inverter)			
	m/l'	11.8	18.9	35.4 (↗26)	
	kW	1.85 (inverter)			
	n/l'	0.23	0.58	1.15	
	kW	1.2 (inverter)			
	min	4			
	kW	1.5			
	4350 kg		3700 kg + 3800 kg		3000 kg + 4500 kg
	0 kg	1800 kg	3700 kg	3000 kg	
P1	990 kg	2490 kg	4045 kg	3445 kg	
P2	3485 kg	3785 kg	4130 kg	4030 kg	

